

Rod ends dimension series K

Standard	P. 1-10
Stainless steel	P. 1-14
Stainless steel copper alloys free	P. 1-18
Pneumatic	P. 1-20
Pneumatic stainless steel	P. 1-24
Pneumatic stainless steel copper alloys free	P. 1-28
ASKUROL ball bearing	P. 1-30
ASKUROL roller bearing	P. 1-32
RS	P. 1-34

Spherical bearings dimension series K

Type G	P. 1-38, 1-40
Type S	P. 1-39, 1-41
Stainless steel type G	P. 1-42, 1-44
Stainless steel type S	P. 1-43, 1-45
Stainless steel type G copper alloys free	P. 1-46
Stainless steel type S copper alloys free	P. 1-47
RS	P. 1-48

Rod ends dimension series E	P. 1-50
------------------------------------	---------

Spherical bearings dimension series E,G,W	P. 1-54
--	---------



Rod ends dimension series K

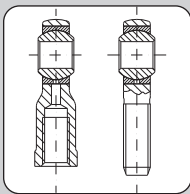

Standard
Stainless steel
Stainless steel
copper alloys free

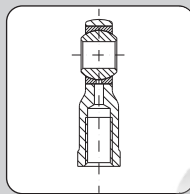

Pneumatic
Pneumatic
stainless steel
Pneumatic
stainless steel
copper alloys free

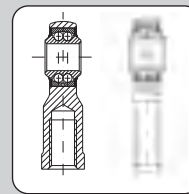

ASKUROL
ball bearing

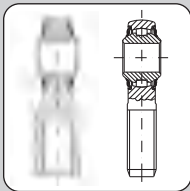

ASKUROL
roller bearing

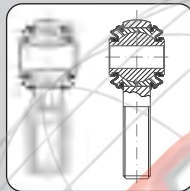

RS

Spherical bearings dimension series K

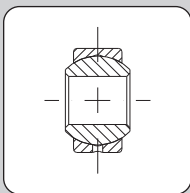

Type G
Stainless steel
type G
Stainless steel
type G copper
alloys free

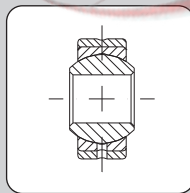

Type S
Stainless steel
type S
Stainless steel
type S copper
alloys free

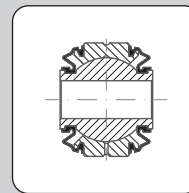

RS

Rod ends dimension series E

Spherical bearings dimension series E,G,W

Selection of rod end and spherical bearing size

The selection and determination of spherical bearing and rod end sizes in Schedule K must be based on the specified load capacity, applied loads and requirements for useful life and operating safety.

The load ratings specified in the tables serve as definitive characteristic and arithmetic values for the load capacity of the spherical bearings and rod ends.

Load ratings from different manufacturers cannot always be compared with each other, since no standardised load rating definition exists for spherical bearings and rod ends.

The following conditions are used as a basis for the load ratings of Askubal heavy-duty spherical bearings and rod ends:

Static load capacity C_0 (plain bearings)

The static load capacity C_0 is the radially acting static load which does not cause any permanent deformation of the components when the spherical bearing or rod end is stationary, i.e. the load condition without pivoting, swivelling or tilting movements. It is also a precondition here that the operating temperature must be in the normal room temperature range and the surrounding components must possess sufficient stability.

The static load capacity may vary by lower or higher temperature according to the material.

Static load capacity C_0 (roller bearings)

In the case of Askubal rod ends with roller bearings, the static load rating is the load at which the overall permanent deformation of rolling elements and raceways is max. 0.0001 of the rolling element diameter.

Dynamic load capacity C (plain bearings)

Dynamic load ratings serve as arithmetic values for calculation of the service life of dynamically-loaded spherical bearings and rod ends. The values themselves do not provide any information about the effective dynamic load capacity of the spherical bearing or rod end. To obtain this information, it is necessary to take into account the additional influencing factors such as load type, swivel or tilt angle, speed characteristic, max. permitted bearing clearance, max. permitted bearing friction, lubrication conditions and temperature, etc.

Dynamic load capacities depend on the definition used to calculate them. Comparison of values is not always possible owing to the different definitions used by various manufacturers, and because the load capacities are often determined under completely different test conditions.

Dynamic load capacity C (roller bearings)

In the case of Askubal rod ends with roller bearings, the dynamic load capacity is the load at which 90% of a large quantity of identical rod ends reach 1 million revolutions before they fail owing to fatigue of the rolling surfaces.

Operating temperature

All Askubal spherical bearings and rod ends can be used without restriction in an operating temperature range of between -10 °C bis $+80\text{ °C}$. Different operating temperatures occur a decrease of load capacity of the rod end housing and the bearing therefore the useful life will be reduced too.

Rod end selection

When choosing a rod end be sure that the real load is always explicitly less than the maximum load capacity of the rod end.

Load direction

The load is of prime importance in the selection of bearing size, however the load direction is also important. A differentiation is made between the following load directions.

Bearing movement

A differentiation is made between the following bearing movements in spherical bearings:

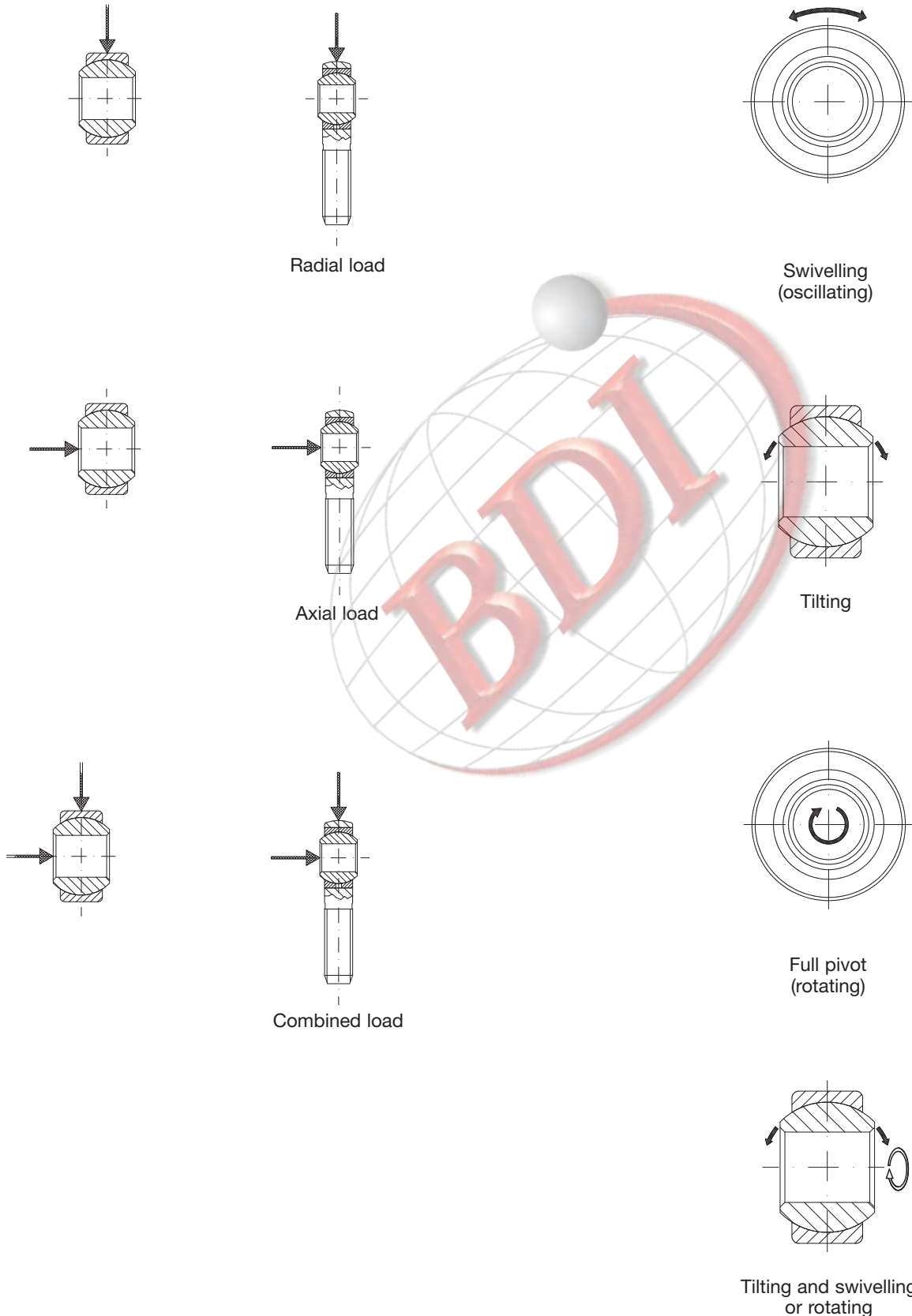

Housing load capacity

Depending on the load type, the following load factors must be taken into account for the permitted max. radial housing load capacity $F_{r\text{ perm}}$:

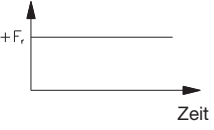
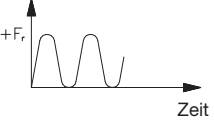
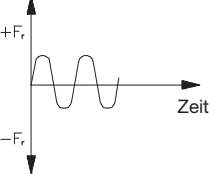
Load type		Load factor S_B	Load factor S_K
	constant	1	0.7
	pulsating	0.333	0.7
	alternating	0.166	0.7

The load factor S_K is valid for rod ends with male thread and lubricating hole or lubricating nipple. The named load factors should be used to value the limited load capacity. Load factors for shock load, also caused by increasing the bearing clearance or by an additional load due to simultaneous swivel movements are not included. The load factor S_K , which considers the weakening of the unit can only be a rough reference value. In extreme operating conditions specially in cases where the life and safety of individuals is placed at risk, practice-orientated tests must be verified.

The permitted radial housing load capacity $F_{r\text{ perm}}$ is reduced as follows:

$$F_{r\text{ perm}} [\text{kN}] = \text{stat. load } C_0 [\text{kN}] \cdot S_B \cdot (S_K)$$

Note: Caution! Special requirements must be fulfilled for use of these components in aircraft. For this reason, we can accept no product liability for applications of this kind.

Spherical bearing load capacity

A mounted spherical bearing has a considerably higher static load capacity than a rod end housing, as can be seen in a comparison of the static load ratings for rod ends and for the equivalent spherical bearings.

Dynamic load

Basically an exact calculation of useful life is not possible, because of the conditions of use and the factors of influence which are often very hard to collect. Therefore experiences of already performed and comparable applications are highly important. To decide the size of bearing you further have to consider the following criteria:

- the load capacity of the housing
- the selection of mating materials for the spherical bearing

We will best possibly support your selection. Please ask us for help.

Bearing clearance

Bearing clearance is defined as the radial and axial freedom of motion of the inner ring (see illustration).

Reduced or enlarged bearing clearances (C3 or C2) are available on request.

In plain bearings the axial clearance could be several times higher than the radial clearance.

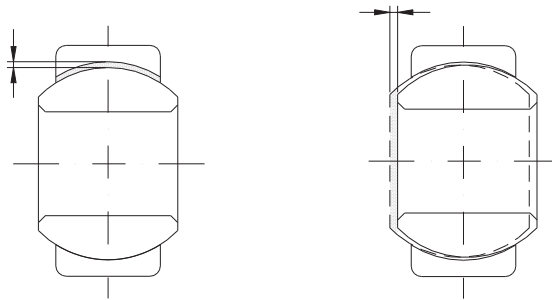

Radial clearance

Axial clearance

Radial clearance

Spherical bearings to DIN ISO 12240-1, Dimension Series K

Bearing bore		Mating materials steel on high-duty bronze						Mating materials steel on PTFE					
d		C2*		normal		C3*		C2*		normal		C3*	
over mm	incl.	min μm	max	min	max	min	max	min	max	min	max	min	max
3	6	4	34	10	50	42	72	5	30	20	50	40	65
8	10	5	41	13	61	52	88	10	50	40	80	70	100
12	18	6	49	16	75	64	107	15	60	50	100	90	130
20	30	7	59	20	92	77	120	30	70	60	110	100	140
35	50	9	71	25	112	98	150	40	80	70	140	130	180

Spherical bearing to DIN ISO 12240-1, Dimension Series E

Bearing bore		Mating materials steel on steel						Mating materials steel on PTFE					
d		C2*		normal		C3*		C2*		normal		C3*	
over mm	incl.	min μm	max	min	max	min	max	min	max	min	max	min	max
2,5	12	8	32	32	68	68	104	0	25	0	32	15	45
12	20	10	40	40	82	82	124	0	30	0	40	20	60
20	35	12	50	50	100	100	150	0	35	0	50	25	65
35	60	15	60	60	120	120	180	0	40	0	60	30	80
60	90	18	72	72	142	142	212	0	50	0	72	35	90
90	140	18	85	85	165	165	245	0	60	0	85	40	100

Spherical bearing to DIN ISO 12240-1, Dimension Series G

Bearing bore		Mating materials steel on steel					
d		C2*		normal		C3*	
over mm	incl.	min μm	max	min	max	min	max
2.5	10	8	32	32	68	68	104
10	17	10	40	40	82	82	124
17	30	12	50	50	100	100	150
30	50	15	60	60	120	120	180
50	80	18	72	72	142	142	212
80	120	18	85	85	165	165	245

Spherical bearing to DIN ISO 12240-1, Dimension Series W

Bearing bore		Mating materials steel on steel					
d		C2*		normal		C3*	
over mm	incl.	min μm	max	min	max	min	max
2.5	12	8	32	32	68	68	104
12	20	10	40	40	82	82	124
20	32	12	50	50	100	100	150
32	50	15	60	60	120	120	180
50	90	18	72	72	142	142	212
90	125	18	85	85	165	165	245

*) on request

Rod ends to DIN ISO 12240-4, Dimension Series K

Bearing bore		Mating materials steel on high-duty bronze				Mating materials steel on PTFE			
d		normal		C3*		normal		C3*	
over mm	incl.	min	max	min	max	min	max	min	max
3	6	2	34	12	65	3	35	10	50
8	10	3	41	20	78	5	40	15	55
12	18	3	49	25	93	5	45	15	65
20	30	4	59	30	103	10	55	20	75
35	50	5	71	35	125	10	60	20	80

Rod ends to DIN ISO 12240-4, Dimension Series E

Bearing bore		Mating materials steel on steel				Mating materials steel on PTFE			
d		normal		C3*		normal		C3*	
over mm	incl.	min	max	min	max	min	max	min	max
2.5	12	16	68	34	104	0	25	10	40
12	20	20	82	41	124	0	30	10	55
20	35	25	100	50	150	0	35	15	60

Rod ends on antifriction bearing basis, mounting sizes to DIN ISO 12240-4

Bearing bore		Ball bearing						Roller bearing					
d		C2*		normal		C3*		C2*		normal		C3*	
over mm	incl.	min μm	max	min	max	min	max	min	max	min	max	min	max
	30	5	30	15	40	35	50	10	30	20	50	45	60

*) nur auf Anfrage

In antifriction bearings the axial clearance could be several times higher than the radial clearance.

Tilt angle limitation

For all Askubal spherical bearings and Askuro rods ends, the maximum tilt angle specified in the tables must not be exceeded while mounting or during operation, otherwise the bearing or washers and cover washers may be damaged. The assembly must be constructed so that the rod end or spherical bearing is effectively prevented from moving further than the given angle (Fig. a). At the same time, however, no major forces may be applied to the housing. It is also important to ensure that there is always sufficient space available for the seal (particularly with RS models), in order to prevent contact with the surrounding components (Fig. b).

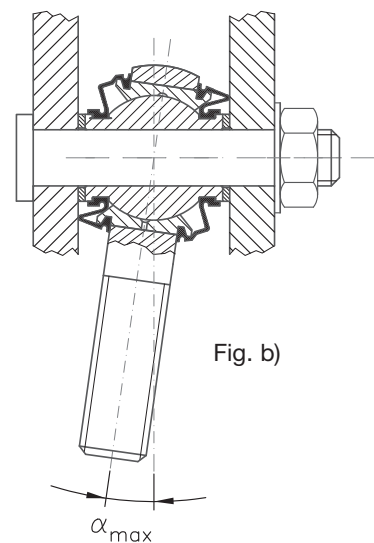
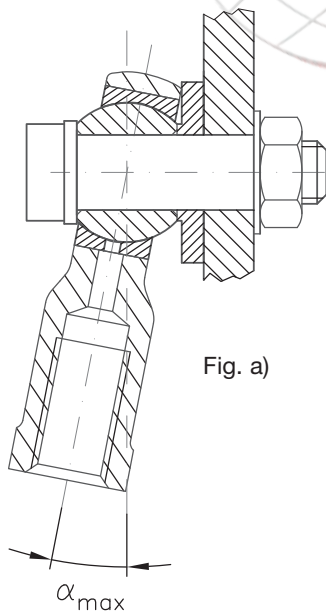

Mounting instructions

Installation

All Askubal spherical bearings and rod ends are very high precision, ready-to-fit bearing elements. For this reason, they must be stored carefully and installed correctly. It is important to comply with the following points:

1. The spherical bearings and rod ends must be kept in their original packaging until shortly before their installation, so that they continue to be effectively preserved for as long as possible. Ensure during the installation process that foreign particles are on no account allowed to enter the outer ring of the bearing.
2. The forces required for installation and removal should on no account be transmitted from the spherical form to the bearing shells or raceways of the bearing outer ring.
3. In order for the spherical bearings to run smoothly, the sliding movement must take place between the sliding faces of the bearing inner ring and outer ring. Sliding movements on the shaft or in the housing cause damage and premature failure. For this reason, it is essential for there to be an interference fit between the bearing housing and bearing outer ring and between the bearing inner ring and the connection shaft. This can be achieved by using tight fits and with axial tensioning of the bearing rings. However, the consequence of using tight fits is an alteration in the bearing clearance. Too high interference between the housing and the bearing outer ring causes contraction of the outer ring. Too high interference between the connection shaft and the inner ring causes the inner ring to expand.

Maintenance and lubrication

The useful life of all spherical bearings and rod ends with metallic mating materials is greatly dependent on regular lubrication. A one-off initial grease filling is only adequate if operating loads are very low. The effectiveness of lubrication is mainly dependent on the load, type of load (constant, pulsating or alternating), the swivel angle and sliding speed. Numerous tests in our ASK laboratory have shown that small swivel angles and both very low and very high sliding speeds have an unfavourable effect on the formation of a film of lubricant. A load which acts in one direction only is also unfavourable compared to an alternating load. To ensure optimum and even distribution of the lubricant, initial lubrication and subsequent lubrication should be carried out with the spherical bearing or rod end in an unloaded condition.

Note

In order to avoid incompatibility of various lubricants that may be used by ASK and the customer, spherical bearings and rod ends are supplied only with an anticorrosive coating. For this reason, spherical bearings and rod ends which need maintenance should be given initial lubrication before commissioning or directly after installation. We recommend carrying out initial lubrication after a running-in time of approx. 1 hour. Whenever this lubrication is carried out, the bearing must be in an unloaded condition, so that the lubricant can spread without obstruction. Lubrication should continue until the lubricant emerges between the bearing outer ring and the inner ring. For rod ends with a female thread, it is also advisable to fill the space in the shank thread with lubricant up to the threaded connection journal before installation. This reduces the amount of work involved in lubricating with the lubricating nipple.

Mating materials steel on high-duty bronze

We recommend using corrosion inhibiting, pressure-resistant lithium-base greases or lithium complex metallic soap greases for lubrication of this material combination. The operating temperature range should be between -20°C and $+110^{\circ}\text{C}$. It is possible to reduce friction and increase the useful life of components which are used under load conditions in the upper limit range by using solid lubricants. These are available on request.

Mating materials steel on PTFE

This material combination is distinguished by its low friction. The antifriction film is made of a material which makes lubrication unnecessary, so that maintenance-free operation is possible.

Askuro antifriction bearings

Ball bearings: These rod ends are given permanent lubrication with a lithium soap grease. Subsequent lubrication is not required. There is, however, a version available for a swivel angle of $<5^{\circ}$ which does require subsequent lubrication.

Roller bearings: These rod ends are given initial lubrication with a lithium soap grease. If they are used in heavy operating conditions, these rod ends can be relubricated through the fitted lubricating nipples.







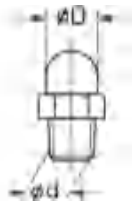

ASKUBAL Rod ends and spherical bearings

Please note, that the use of a non standard lubricating nipple (DIN 3405 shape D) causes a cross sectional variation for

housings with male thread which means a reduction of the static load capacity C_0 .

Lubricating nipple shapes

DIN-No.	Designation indicate by ordering, if deviates from standard rod end	d mm	D	
DIN 3402 shape A		SN 3402 M 6	M 6	
		SN 3402 M 8 x 1	M 8 x 1	
		SN 3402 M 10 x 1	M 10 x 1	
DIN 3402 shape D		SN 3402 D	5.0	
		SN 3402 D 6 x 6.5	6.0	
DIN 3405 shape A		SN 3405 M 6	M 6	
		SN 3402 M 8 x 1	M 8 x 1	
DIN 3405 shape D		Lubricating nipple for standard rod ends		
		SN 3405 D 3.5 x 5	3.5	
DIN 71 412 shape A		SN	M 6	
		SN	M 5	
		SNA 5	5.0	8.0
		SNA M 8 x 1	M 8 x 1	
		SNA R 1/8"	R 1/8"	
DIN 71 412 shape B		SNB	M 6	
		SNB M 8 x 1	M 8 x 1	

**You have problems which
have not been solved so far?
– Ask us!**



G-KUI 10-96-1.1



threaded pin
DIN 914 M4x4

31

with Loctite 638
locked against
rotation



G-KUA 10-96-1.2

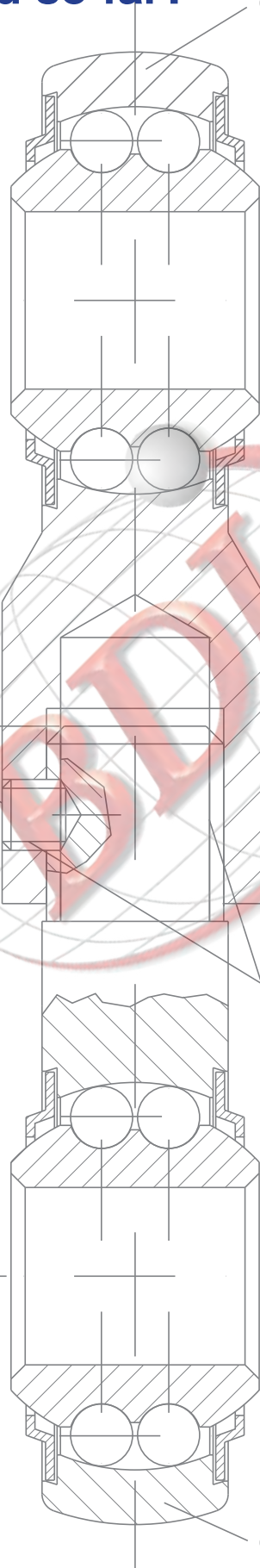

Mating Materials:
Steel on high-duty bronze
Maintenance required

Standard
 DIN ISO 12240-4
 dimension series K

Inner ring: Antifriction bearing steel, hardened, ground and polished.

Outer ring: Sliding face made of high-duty bronze. Lubricant is distributed via the lubrication groove in the outer ring.

Housing: Sizes 3 to 12 free-cutting steel, sizes 14 to 50 tempering steel (standardised), all sizes galvanized and chromatised. The spherical bearing is pressed into the housing and caulked at both sides.

Lubrication nipple: Sizes 3 and 5 without lubrication nipple. Sizes 6 to 50 lubrication nipple DIN 3405, shape D. Further lubrication nipple shapes available on request.

Female thread

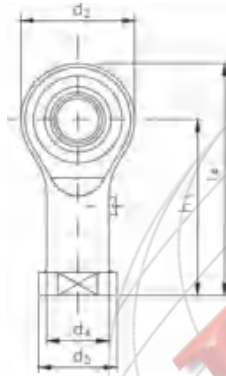
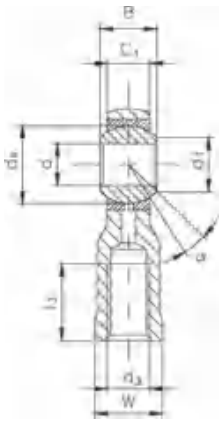

Designation	d	d ₃	B	C ₁	d ₁ ≈	
Righthand thread	Lefthand thread	mm	mm	mm	mm	
KI 3	KIL 3	3	M3	6	4.50	5.1
KI 5	KIL 5	5	M5	8	6.00	7.7
KI 6	KIL 6	6	M6	9	6.75	8.9
KI 8	KIL 8	8	M8	12	9.00	10.3
KI 10	KIL 10	10	M10	14	10.50	12.9
KI 12	KIL 12	12	M12	16	12.00	15.4
KI 14	KIL 14	14	M14	19	13.50	16.8
KI 16	KIL 16	16	M16	21	15.00	19.3
KI 18	KIL 18	18	M18x1.5	23	16.50	21.8
KI 20	KIL 20	20	M20x1.5	25	18.00	24.3
KI 22	KIL 22	22	M22x1.5	28	20.00	25.8
KI 25	KIL 25	25	M24x2	31	22.00	29.5
KI 30	KIL 30	30	M30x2	37	25.00	34.8
KI 35	KIL 35	35	M36x2	43	28.00	37.7*
KI 40	KIL 40	40	M42x2	49	33.00	45.2*
KI 50	KIL 50	50	M48x2	60	45.00	56.6*

*) deviates from standard

Male thread

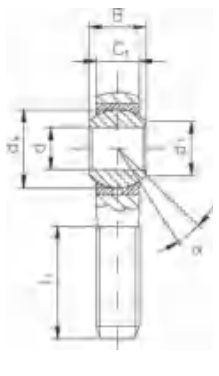

Designation	d	d ₃	B	C ₁	d ₁ ≈	
Righthand thread	Lefthand thread	mm	mm	mm	mm	
KA 3	KAL 3	3	M3	6	4.50	5.1
KA 5	KAL 5	5	M5	8	6.00	7.7
KA 6	KAL 6	6	M6	9	6.75	8.9
KA 8	KAL 8	8	M8	12	9.00	10.3
KA 10	KAL 10	10	M10	14	10.50	12.9
KA 12	KAL 12	12	M12	16	12.00	15.4
KA 14	KAL 14	14	M14	19	13.50	16.8
KA 16	KAL 16	16	M16	21	15.00	19.3
KA 18	KAL 18	18	M18x1.5	23	16.50	21.8
KA 20	KAL 20	20	M20x1.5	25	18.00	24.3
KA 22	KAL 22	22	M22x1.5	28	20.00	25.8
KA 25	KAL 25	25	M24x2	31	22.00	29.5
KA 30	KAL 30	30	M30x2	37	25.00	34.8
KA 35	KAL 35	35	M36x2	43	28.00	37.7*
KA 40	KAL 40	40	M42x2	49	33.00	45.2*
KA 50	KAL 50	50	M48x2	60	45.00	56.6*

*) deviates from standard

Special versions:

- **Version -V:**
as standard, but housing heat-treated,
for static load capacity see **-V** load rating stat **C0**
- **Version -L:**
as standard, but housing made from high-grade tempering steel (heat-treated),
for static load capacity see **-L** load rating stat **C0**

Further versions available on request. E.g.:

- Housing crack-tested
- Sliding face of inner ring hard chromium plated
- Special surface coating of housing

d ₂ max.	d ₄ ≈	d ₅	dk	h ₁	l ₃ min.	l ₄ ≈	W	Load ratings static C ₀			Tilt angle	Weight
								Standard	-V	-L		
mm	mm	mm	mm	mm	mm	mm	mm	kN	kN	kN	°	kg
15	6.5	8	7.9	21	8	28.5	7	4	•	•	13	0.008
19	9.0	11	11.1	27	8	36.5	9	6	•	•	13	0.017
21	10.0	13	12.7	30	9	40.5	11	7	•	•	13	0.025
25	12.5	16	15.8	36	12	48.5	14	12	16	21	13	0.043
29	15.0	19	19.0	43	15	57.5	17	15	19	27	13	0.072
33	17.5	22	22.2	50	18	66.5	19	23	25	35	13	0.107
37	20.0	25	25.4	57	21	75.5	22	24	34	46	15	0.160
43	22.0	27	28.5	64	24	85.5	22	34	43	57	15	0.210
47	25.0	31	31.7	71	27	94.5	27	39	49	77	15	0.295
51	27.5	34	34.9	77	30	102.5	30	42	50	78	15	0.380
55	30.0	37	38.1	84	33	111.5	32	54	70	101	15	0.490
61	33.5	42	42.8	94	36	124.5	36	60	78	131	15	0.650
71	40.0	50	50.8	110	45	145.5	41	82	107	182	15	1.150
81	46.0	58	57.1	125	56	165.5	50	96	•	•	16	1.600
91	53.0	65	66.6	142	60	187.5	55	145	•	•	17	2.400
117	65.0	75	82.5	160	65	218.5	65	209	•	•	12	5.000

• not available

d ₂ max.	dk	h	l ₁ min.	l ₂ ≈	Load ratings static C ₀			Tilt angle	Weight	
					Standard	-V	-L			
mm	mm	mm	mm	mm	mm	kN	kN	kN	°	kg
15	7.9	27	15	34.0	1	•	•	13	0.005	
19	11.1	33	19	42.5	3	•	•	13	0.013	
21	12.7	36	21	46.5	4	•	•	13	0.019	
25	15.8	42	25	54.5	8	10	17	13	0.032	
29	19.0	48	28	62.5	13	17	25	13	0.054	
33	22.2	54	32	70.5	21	22	33	13	0.085	
37	25.4	60	36	78.5	22	31	44	15	0.125	
43	28.5	66	37	87.5	33	43	57	15	0.185	
47	31.7	72	41	95.5	39	49	77	15	0.260	
51	34.9	78	45	103.5	42	50	78	15	0.340	
55	38.1	84	48	111.5	54	70	101	15	0.435	
61	42.8	94	55	124.5	60	78	131	15	0.590	
71	50.8	110	66	145.5	82	107	182	15	1.060	
81	57.0	140	85	180.5	96	•	•	16	1.640	
91	66.0	150	90	195.5	132	•	•	17	2.300	
117	82.0	185	105	243.5	209	•	•	12	4.800	

• not available

ASKUBAL Rod ends and spherical bearings

Mating materials:
Steel on PTFE
Maintenance-free

Standard
 DIN ISO 12240-4
 dimension series K

Inner ring: Antifriction bearing steel, hardened, ground and polished.

Outer ring: Steel lined with an antifriction film, consisting of PTFE.

Housing: Sizes 5 to 12 free-cutting steel, sizes 14 to 50 tempering steel (standardised), all sizes galvanized and chromatised. The spherical bearing is pressed into the housing and caulked at both sides.

Female thread

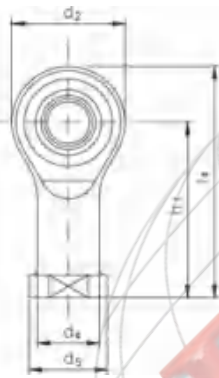
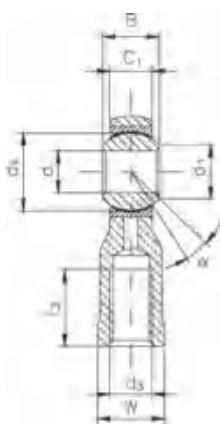

Designation		d	d ₃	B	C ₁	d ₁ ≈
Righthand thread	Lefthand thread	mm	mm	mm	mm	mm
KI 5-D	KIL 5-D	5	M5	8	6.00	7.7
KI 6-D	KIL 6-D	6	M6	9	6.75	8.9
KI 8-D	KIL 8-D	8	M8	12	9.00	10.3
KI 10-D	KIL 10-D	10	M10	14	10.50	12.9
KI 12-D	KIL 12-D	12	M12	16	12.00	15.4
KI 14-D	KIL 14-D	14	M14	19	13.50	16.8
KI 16-D	KIL 16-D	16	M16	21	15.00	19.3
KI 18-D	KIL 18-D	18	M18x1.5	23	16.50	21.8
KI 20-D	KIL 20-D	20	M20x1.5	25	18.00	24.3
KI 22-D	KIL 22-D	22	M22x1.5	28	20.00	25.8
KI 25-D	KIL 25-D	25	M24x2	31	22.00	29.5
KI 30-D	KIL 30-D	30	M30x2	37	25.00	34.8
KI 35-D	KIL 35-D	35	M36x2	43	28.00	37.7*
KI 40-D	KIL 40-D	40	M42x2	49	33.00	45.2*
KI 50-D	KIL 50-D	50	M48x2	60	45.00	56.6*

*) deviates from standard

Male thread

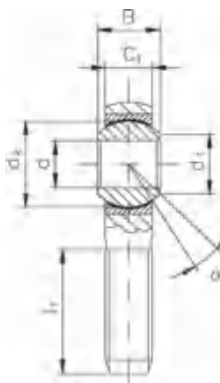

Designation		d	d ₃	B	C ₁	d ₁ ≈
Righthand thread	Lefthand thread	mm	mm	mm	mm	mm
KA 5-D	KAL 5-D	5	M5	8	6.00	7.7
KA 6-D	KAL 6-D	6	M6	9	6.75	8.9
KA 8-D	KAL 8-D	8	M8	12	9.00	10.3
KA 10-D	KAL 10-D	10	M10	14	10.50	12.9
KA 12-D	KAL 12-D	12	M12	16	12.00	15.4
KA 14-D	KAL 14-D	14	M14	19	13.50	16.8
KA 16-D	KAL 16-D	16	M16	21	15.00	19.3
KA 18-D	KAL 18-D	18	M18x1.5	23	16.50	21.8
KA 20-D	KAL 20-D	20	M20x1.5	25	18.00	24.3
KA 22-D	KAL 22-D	22	M22x1.5	28	20.00	25.8
KA 25-D	KAL 25-D	25	M24x2	31	22.00	29.5
KA 30-D	KAL 30-D	30	M30x2	37	25.00	34.8
KA 35-D	KAL 35-D	35	M36x2	43	28.00	37.7*
KA 40-D	KAL 40-D	40	M42x2	49	33.00	45.2*
KA 50-D	KAL 50-D	50	M48x2	60	45.00	56.6*

*) deviates from standard

Special versions:

- **Version -DMS:**
as standard, but outer ring made of brass
 - **Version -DV:**
as standard, but housing heat-treated,
for static load capacity see **-V** load rating stat **C0**
 - **Version -DL:**
as standard, but housing made from high-grade tempering steel (heat-treated),
for static load capacity see **-L** load rating stat **C0**
- Further versions available on request. E.g.:
- Housing crack-tested
 - Sliding face of inner ring hard chromium plated
 - Special surface coating of housing

d ₂ max.	d ₄ ≈	d ₅	dk	h ₁	l ₃ min.	l ₄ ≈	W	Load ratings static C ₀			Tilt angle	Weight
								Standard	-V	-L		
mm	mm	mm	mm	mm	mm	mm	mm	kN	kN	kN	α°	kg
19	9.0	11	11.1	27	8	36.5	9	6	•	•	13	0.017
21	10.0	13	12.7	30	9	40.5	11	7	•	•	13	0.025
25	12.5	16	15.8	36	12	48.5	14	12	16	21	13	0.043
29	15.0	19	19.0	43	15	57.5	17	15	19	27	13	0.072
33	17.5	22	22.2	50	18	66.5	19	23	25	35	13	0.107
37	20.0	25	25.4	57	21	75.5	22	24	34	46	15	0.160
43	22.0	27	28.5	64	24	85.5	22	34	43	57	15	0.210
47	25.0	31	31.7	71	27	94.5	27	39	49	77	15	0.295
51	27.5	34	34.9	77	30	102.5	30	42	50	78	15	0.380
55	30.0	37	38.1	84	33	111.5	32	54	70	101	15	0.490
61	33.5	42	42.8	94	36	124.5	36	60	78	131	15	0.650
71	40.0	50	50.8	110	45	145.5	41	82	107	182	15	1.150
81	46.0	58	57.1	125	56	165.5	50	96	•	•	16	1.600
91	53.0	65	66.6	142	60	187.5	55	132	•	•	17	2.400
117	65.0	75	82.5	160	65	218.5	65	209	•	•	12	5.000

• not available

d ₂ max.	dk	h	l ₁ min.	l ₂ ≈	Load ratings static C ₀			Tilt angle	Weight	
					Standard	-V	-L			
mm	mm	mm	mm	mm	mm	kN	kN	kN	α°	kg
19	11.1	33	19	42.5	4	•	•	13	0.013	
21	12.7	36	21	46.5	6	•	•	13	0.019	
25	15.8	42	25	54.5	10	12	19	13	0.032	
29	19.0	48	28	62.5	15	19	27	13	0.054	
33	22.2	54	32	70.5	23	25	35	13	0.085	
37	25.4	60	36	78.5	24	34	46	15	0.125	
43	28.5	66	37	87.5	33	43	57	15	0.185	
47	31.7	72	41	95.5	39	49	77	15	0.260	
51	34.9	78	45	103.5	42	50	78	15	0.340	
55	38.1	84	48	111.5	54	70	101	15	0.435	
61	42.8	94	55	124.5	60	78	131	15	0.590	
71	50.8	110	66	145.5	82	107	182	15	1.060	
81	57.1	140	85	180.5	96	•	•	16	1.640	
91	66.6	150	90	195.5	132	•	•	17	2.300	
117	82.5	185	105	243.5	209	•	•	12	4.800	

• not available

Mating materials:
Stainless steel on high-duty bronze
Maintenance required

Stainless steel
 DIN ISO 12240-4
 dimension series K

Inner ring: Stainless steel, hardened, ground and polished.

Outer ring: Sliding face made of high-duty bronze. Lubricant is distributed via the lubricating groove in the outer ring.

Housing: Stainless steel. The spherical bearing is pressed into the housing and caulked at both sides.

Lubrication nipple: Size 5 without lubrication nipple. Sizes 6 to 30 lubricating nipple DIN 3405, shape D. Further lubricating nipple shapes available on request.

Female thread

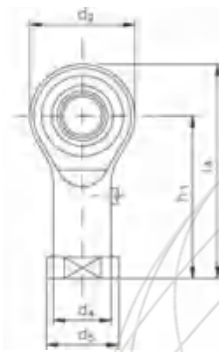
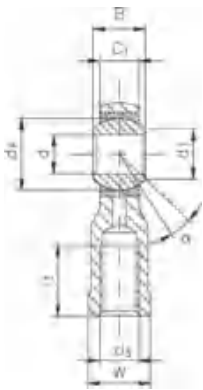

Designation		d	d ₃	B	C ₁	d ₁
Righthand thread	Lefthand thread	mm	mm	mm	mm	≈ mm
KI 5-NR	KIL 5-NR	5	M5	8	6.00	7.7
KI 6-NR	KIL 6-NR	6	M6	9	6.75	8.9
KI 8-NR	KIL 8-NR	8	M8	12	9.00	10.3
KI 10-NR	KIL 10-NR	10	M10	14	10.50	12.9
KI 12-NR	KIL 12-NR	12	M12	16	12.00	15.4
KI 14-NR	KIL 14-NR	14	M14	19	13.50	16.8
KI 16-NR	KIL 16-NR	16	M16	21	15.00	19.3
KI 18-NR	KIL 18-NR	18	M18x1.5	23	16.50	21.8
KI 20-NR	KIL 20-NR	20	M20x1.5	25	18.00	24.3
KI 22-NR	KIL 22-NR	22	M22x1.5	28	20.00	25.8
KI 25-NR	KIL 25-NR	25	M24x2	31	22.00	29.5
KI 30-NR	KIL 30-NR	30	M30x2	37	25.00	34.8

Male thread

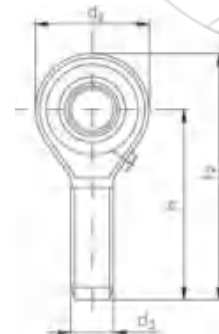
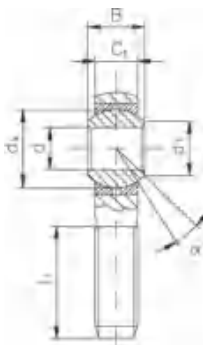

Designation		d	d ₃	B	C ₁	d ₁
Righthand thread	Lefthand thread	mm	mm	mm	mm	≈ mm
KA 5-NR	KAL 5-NR	5	M5	8	6.00	7.7
KA 6-NR	KAL 6-NR	6	M6	9	6.75	8.9
KA 8-NR	KAL 8-NR	8	M8	12	9.00	10.3
KA 10-NR	KAL 10-NR	10	M10	14	10.50	12.9
KA 12-NR	KAL 12-NR	12	M12	16	12.00	15.4
KA 14-NR	KAL 14-NR	14	M14	19	13.50	16.8
KA 16-NR	KAL 16-NR	16	M16	21	15.00	19.3
KA 18-NR	KAL 18-NR	18	M18x1.5	23	16.50	21.8
KA 20-NR	KAL 20-NR	20	M20x1.5	25	18.00	24.3
KA 22-NR	KAL 22-NR	22	M22x1.5	28	20.00	25.8
KA 25-NR	KAL 25-NR	25	M24x2	31	22.00	29.5
KA 30-NR	KAL 30-NR	30	M30x2	37	25.00	34.8

Sizes 18 and 22 only on request.

Special versions:
- Version -R:

as standard, but inner ring hard chromium plated at sliding surface

Further versions are available on request

d_2 max. mm	d_4 ≈ mm	d_5 mm	d_k mm	h_1 mm	l_3 min. mm	l_4 ≈ mm	W mm	Load rating static C_0 kN	Tilt angle α°	Weight kg
19	9.0	11	11.1	27	8	36.5	9	6	13	0.017
21	10.0	13	12.7	30	9	40.5	11	7	13	0.025
25	12.5	16	15.8	36	12	48.5	14	10	13	0.043
29	15.0	19	19.0	43	15	57.5	17	13	13	0.072
33	17.5	22	22.2	50	18	66.5	19	15	13	0.107
37	20.0	25	25.4	57	21	75.5	22	22	15	0.160
43	22.0	27	28.5	64	24	85.5	22	28	15	0.210
47	25.0	31	31.7	71	27	94.5	27	35	15	0.295
51	27.5	34	34.9	77	30	102.5	30	41	15	0.380
55	30.0	37	38.1	84	33	111.5	32	51	15	0.490
61	33.5	42	42.8	94	36	124.5	36	58	15	0.650
71	40.0	50	50.8	110	45	145.5	41	80	15	1.150

d_2 max. mm	d_k mm	h mm	l_1 min. mm	l_2 ≈ mm	Load rating static C_0 kN	Tilt angle α°	Weight kg
19	11.1	33	19	42.5	3	13	0.013
21	12.7	36	21	46.5	4	13	0.019
25	15.8	42	25	54.5	6	13	0.032
29	19.0	48	28	62.5	11	13	0.054
33	22.2	54	32	70.5	15	13	0.085
37	25.4	60	36	78.5	22	15	0.125
43	28.5	66	37	87.5	28	15	0.185
47	31.7	72	41	95.5	35	15	0.260
51	34.9	78	45	103.5	41	15	0.340
55	38.1	84	48	111.5	51	15	0.435
61	42.8	94	55	124.5	58	15	0.590
71	50.8	110	66	145.5	80	15	1.060

ASKUBAL Rod ends and spherical bearings

Mating materials:
Stainless steel on PTFE
Maintenance-free

Stainless steel
 DIN ISO 12240-4
 dimension series K

Inner ring: Stainless steel, hardened, ground and polished.

Outer ring: Brass lined with an antifriction film, consisting of PTFE, outer diameter ground.

Housing: Stainless steel. The spherical bearing is pressed into the housing and caulked at both sides.

Female thread

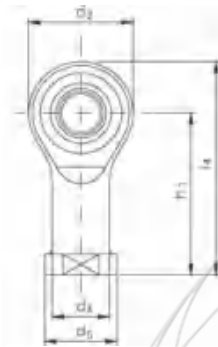
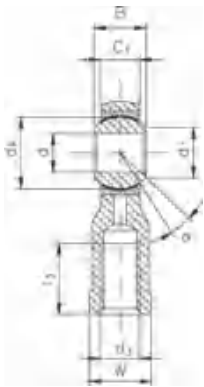

Designation		d	d ₃	B	C ₁	d ₁
Righthand thread	Lefthand thread	mm	mm	mm	mm	≈ mm
KI 5-DNR	KIL 5-DNR	5	M5	8	6.00	7.7
KI 6-DNR	KIL 6-DNR	6	M6	9	6.75	8.9
KI 8-DNR	KIL 8-DNR	8	M8	12	9.00	10.3
KI 10-DNR	KIL 10-DNR	10	M10	14	10.50	12.9
KI 12-DNR	KIL 12-DNR	12	M12	16	12.00	15.4
KI 14-DNR	KIL 14-DNR	14	M14	19	13.50	16.8
KI 16-DNR	KIL 16-DNR	16	M16	21	15.00	19.3
KI 18-DNR	KIL 18-DNR	18	M18x1.5	23	16.50	21.8
KI 20-DNR	KIL 20-DNR	20	M20x1.5	25	18.00	24.3
KI 22-DNR	KIL 22-DNR	22	M22x1.5	28	20.00	25.8
KI 25-DNR	KIL 25-DNR	25	M24x2	31	22.00	29.5
KI 30-DNR	KIL 30-DNR	30	M30x2	37	25.00	34.8

Male thread

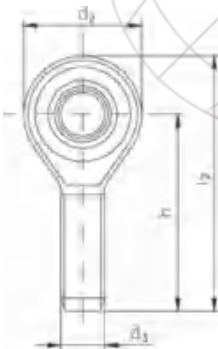
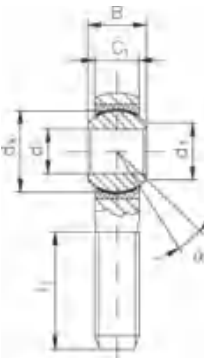

Designation		d	d ₃	B	C ₁	d ₁
Righthand thread	Lefthand thread	mm	mm	mm	mm	≈ mm
KA 5-DNR	KAL 5-DNR	5	M5	8	6.00	7.7
KA 6-DNR	KAL 6-DNR	6	M6	9	6.75	8.9
KA 8-DNR	KAL 8-DNR	8	M8	12	9.00	10.3
KA 10-DNR	KAL 10-DNR	10	M10	14	10.50	12.9
KA 12-DNR	KAL 12-DNR	12	M12	16	12.00	15.4
KA 14-DNR	KAL 14-DNR	14	M14	19	13.50	16.8
KA 16-DNR	KAL 16-DNR	16	M16	21	15.00	19.3
KA 18-DNR	KAL 18-DNR	18	M18x1.5	23	16.50	21.8
KA 20-DNR	KAL 20-DNR	20	M20x1.5	25	18.00	24.3
KA 22-DNR	KAL 22-DNR	22	M22x1.5	28	20.00	25.8
KA 25-DNR	KAL 25-DNR	25	M24x2	31	22.00	29.5
KA 30-DNR	KAL 30-DNR	30	M30x2	37	25.00	34.8

Sizes 18 and 22 only on request.

Special versions:
- Version -DR:

as standard, but inner ring hard chromium plated at sliding surface

Further versions are available on request

d_2 max. mm	d_4 ≈ mm	d_5 mm	d_k mm	h_1 mm	l_3 min. mm	l_4 ≈ mm	W mm	Load rating static C_0 kN	Tilt angle α°	Weight kg
19	9.0	11	11.1	27	8	36.5	9	6	13	0.017
21	10.0	13	12.7	30	9	40.5	11	7	13	0.025
25	12.5	16	15.8	36	12	48.5	14	10	13	0.043
29	15.0	19	19.0	43	15	57.5	17	13	13	0.072
33	17.5	22	22.2	50	18	66.5	19	15	13	0.107
37	20.0	25	25.4	57	21	75.5	22	22	15	0.160
43	22.0	27	28.5	64	24	85.5	22	28	15	0.210
47	25.0	31	31.7	71	27	94.5	27	35	15	0.295
51	27.5	34	34.9	77	30	102.5	30	41	15	0.380
55	30.0	37	38.1	84	33	111.5	32	51	15	0.490
61	33.5	42	42.8	94	36	124.5	36	58	15	0.650
71	40.0	50	50.8	110	45	145.5	41	80	15	1.150

d_2 max. mm	d_k mm	h mm	l_1 min. mm	l_2 ≈ mm	Load rating static C_0 kN	Tilt angle α°	Weight kg
19	11.1	33	19	42.5	4	13	0.013
21	12.7	36	21	46.5	6	13	0.019
25	15.8	42	25	54.5	8	13	0.032
29	19.0	48	28	62.5	12	13	0.054
33	22.2	54	32	70.5	15	13	0.085
37	25.4	60	36	78.5	22	15	0.125
43	28.5	66	37	87.5	28	15	0.185
47	31.7	72	41	95.5	35	15	0.260
51	34.9	78	45	103.5	41	15	0.340
55	38.1	84	48	111.5	51	15	0.435
61	42.8	94	55	124.5	58	15	0.590
71	50.8	110	66	145.5	80	15	1.060

Mating materials:
Stainless steel on PTFE
Maintenance-free

Stainless steel
copper alloys free
DIN ISO 12240-4
series K

Inner ring: Stainless steel, hardened, ground and polished.
Outer ring: Stainless steel lined with an antifriction film, consisting of PTFE, outer diameter ground.
Housing: Stainless steel. The spherical bearing is pressed into the housing and caulked at both sides.

Female thread

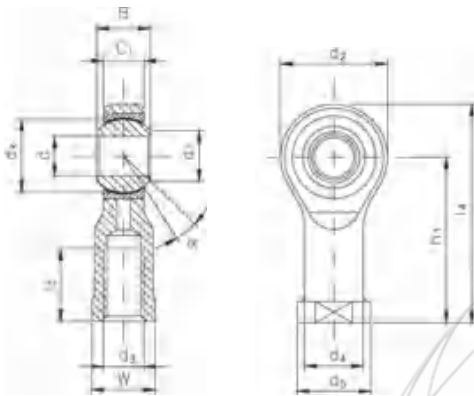

Designation		d	d ₃	B	C ₁	d ₁ ≈ mm
Righthand thread	Lefthand thread	mm	mm	mm	mm	mm
KI 5-DNRBF	KIL 5-DNRBF	5	M5	8	6.00	7.7
KI 6-DNRBF	KIL 6-DNRBF	6	M6	9	6.75	8.9
KI 8-DNRBF	KIL 8-DNRBF	8	M8	12	9.00	10.3
KI 10-DNRBF	KIL 10-DNRBF	10	M10	14	10.50	12.9
KI 12-DNRBF	KIL 12-DNRBF	12	M12	16	12.00	15.4
KI 14-DNRBF	KIL 14-DNRBF	14	M14	19	13.50	16.8
KI 16-DNRBF	KIL 16-DNRBF	16	M16	21	15.00	19.3
KI 18-DNRBF	KIL 18-DNRBF	18	M18x1.5	23	16.50	21.8
KI 20-DNRBF	KIL 20-DNRBF	20	M20x1.5	25	18.00	24.3
KI 22-DNRBF	KIL 22-DNRBF	22	M22x1.5	28	20.00	25.8
KI 25-DNRBF	KIL 25-DNRBF	25	M24x2	31	22.00	29.5
KI 30-DNRBF	KIL 30-DNRBF	30	M30x2	37	25.00	34.8

Male thread

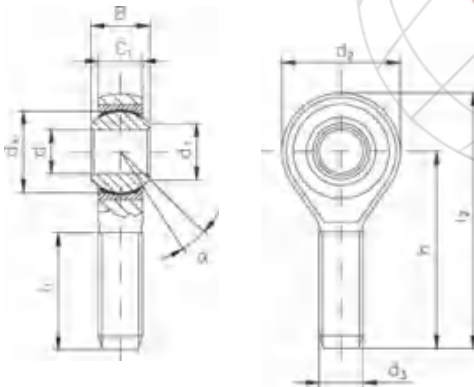

Designation		d	d ₃	B	C ₁	d ₁ ≈ mm
Righthand thread	Lefthand thread	mm	mm	mm	mm	mm
KA 5-DNRBF	KAL 5-DNRBF	5	M5	8	6.00	7.7
KA 6-DNRBF	KAL 6-DNRBF	6	M6	9	6.75	8.9
KA 8-DNRBF	KAL 8-DNRBF	8	M8	12	9.00	10.3
KA 10-DNRBF	KAL 10-DNRBF	10	M10	14	10.50	12.9
KA 12-DNRBF	KAL 12-DNRBF	12	M12	16	12.00	15.4
KA 14-DNRBF	KAL 14-DNRBF	14	M14	19	13.50	16.8
KA 16-DNRBF	KAL 16-DNRBF	16	M16	21	15.00	19.3
KA 18-DNRBF	KAL 18-DNRBF	18	M18x1.5	23	16.50	21.8
KA 20-DNRBF	KAL 20-DNRBF	20	M20x1.5	25	18.00	24.3
KA 22-DNRBF	KAL 22-DNRBF	22	M22x1.5	28	20.00	25.8
KA 25-DNRBF	KAL 25-DNRBF	25	M24x2	31	22.00	29.5
KA 30-DNRBF	KAL 30-DNRBF	30	M30x2	37	25.00	34.8

Sizes 18 and 22 only on request.



Special versions: are available on request

d_2 max. mm	d_4 ≈ mm	d_5 mm	d_k mm	h_1 mm	l_3 min. mm	l_4 ≈ mm	W mm	Load rating static C_0 kN	Tilt angle α°	Weight kg
19	9.0	11	11.1	27	8	36.5	9	6	13	0.017
21	10.0	13	12.7	30	9	40.5	11	7	13	0.025
25	12.5	16	15.8	36	12	48.5	14	10	13	0.043
29	15.0	19	19.0	43	15	57.5	17	13	13	0.072
33	17.5	22	22.2	50	18	66.5	19	15	13	0.107
37	20.0	25	25.4	57	21	75.5	22	22	15	0.160
43	22.0	27	28.5	64	24	85.5	22	28	15	0.210
47	25.0	31	31.7	71	27	94.5	27	35	15	0.295
51	27.5	34	34.9	77	30	102.5	30	41	15	0.380
55	30.0	37	38.1	84	33	111.5	32	51	15	0.490
61	33.5	42	42.8	94	36	124.5	36	58	15	0.650
71	40.0	50	50.8	110	45	145.5	41	80	15	1.150

d_2 max. mm	d_k mm	h mm	l_1 min. mm	l_2 ≈ mm	Load rating static C_0 kN	Tilt angle α°	Weight kg
19	11.1	33	19	42.5	4	13	0.013
21	12.7	36	21	46.5	6	13	0.019
25	15.8	42	25	54.5	8	13	0.032
29	19.0	48	28	62.5	12	13	0.054
33	22.2	54	32	70.5	15	13	0.085
37	25.4	60	36	78.5	22	15	0.125
43	28.5	66	37	87.5	28	15	0.185
47	31.7	72	41	95.5	35	15	0.260
51	34.9	78	45	103.5	41	15	0.340
55	38.1	84	48	111.5	51	15	0.435
61	42.8	94	55	124.5	58	15	0.590
71	50.8	110	66	145.5	80	15	1.060

Mating materials:
Steel on high-duty bronze
Maintenance required

Pneumatic
 Special version for
 pneumatic cylinder

- Inner ring:** Antifriction bearing steel, hardened, ground and polished.
- Outer ring:** Sliding face made of high-duty bronze. Lubricant is distributed via the lubricating groove in the outer ring.
- Housing:** Sizes 5 to 12 free-cutting steel, sizes 16 to 50 tempering steel (standardised), all sizes galvanized and chromatised. The spherical bearing is pressed into the housing and caulked at both sides.
- Lubrication nipple:** Size 5 without lubricating nipple, sizes 6 to 50 lubricating nipple DIN 3405, shape D, further lubricating nipple shapes available on request.

Female thread

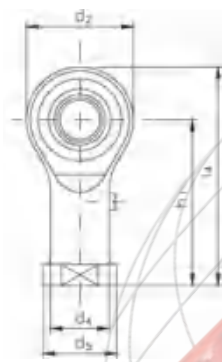
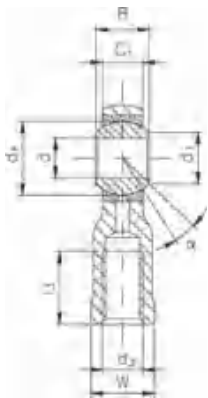

Designation	d	d ₃	B	C ₁	d ₁ ≈
Righthand thread	mm	mm	mm	mm	mm
KI 5-M4	5	M4	8	6.00	7.7
KI 6	6	M6	9	6.75	8.9
KI 8	8	M8	12	9.00	10.3
KI 10-M10x1.25	10	M10x1.25	14	10.50	12.9
KI 12-M12x1.25	12	M12x1.25	16	12.00	15.4
KI 16-M16x1.5	16	M16x1.5	21	15.00	19.3
KI 20	20	M20x1.5	25	18.00	24.3
KI 25	25	M24x2	31	22.00	29.5
KI 30-M27x2	30	M27x2	37	25.00	34.8
KI 35	35	M36x2	43	28.00	37.7
KI 40	40	M42x2	49	33.00	45.2
KI 50	50	M48x2	60	45.00	56.6

Special versions:

- **Version -V:**
as standard, but housing heat-treated,
for static load capacity see **-V** load rating stat **C0**
- Further versions are available on request. E.g.:
- Housing crack-tested
- Sliding face of inner ring hard chromium plated
- Special surface coating of housing

d ₂ max.	d ₄ ≈	d ₅	dk	h ₁	l ₃ min.	l ₄ ≈	W	Load ratings static C ₀		Tilt angle	Weight
								Standard	-V		
mm	mm	mm	mm	mm	mm	mm	mm	kN	kN	α°	kg
19	9.0	11	11.1	27	8	36.5	9	6	•	13	0.016
21	10.0	13	12.7	30	9	40.5	11	7	•	13	0.025
25	12.5	16	15.8	36	12	48.5	14	12	16	13	0.043
29	15.0	19	19.0	43	15	57.5	17	15	19	13	0.072
33	17.5	22	22.2	50	18	66.5	19	23	25	13	0.107
43	22.0	27	28.5	64	24	85.5	22	34	36	15	0.210
51	27.5	34	34.9	77	30	102.5	30	42	50	15	0.380
61	33.5	42	42.8	94	36	124.5	36	60	78	15	0.650
70	40.0	50	50.8	110	45	145.5	41	82	107	15	1.150
81	46.0	58	57.1	125	56	165.5	50	96	•	16	1.600
91	53.0	65	66.6	142	60	187.5	55	145	•	17	2.400
117	65.0	75	82.5	160	65	218.5	65	209	•	12	5.000

Mating materials:
Steel on PTFE
Maintenance-free

Pneumatic
 Special version for
 pneumatic cylinder

Inner ring: Antirfriction bearing steel, hardened, ground and polished.

Outer ring: Steel lined with an antifriction film, consisting of PTFE, outer diameter ground.

Housing: Sizes 5 to 12 free-cutting steel, sizes 16 to 50 tempering steel (standardised), all sizes galvanized and chromatised. The spherical bearing is pressed into the housing and caulked at both sides.

Female thread

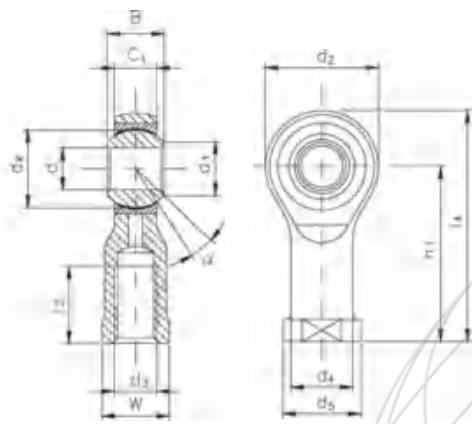

Designation	d	d ₃	B	C ₁	d ₁ ≈
Righthand thread	mm	mm	mm	mm	mm
KI 5-DM4	5	M4	8	6.00	7.7
KI 6-D	6	M6	9	6.75	8.9
KI 8-D	8	M8	12	9.00	10.3
KI 10-DM10x1.25	10	M10x1.25	14	10.50	12.9
KI 12-DM12x1.25	12	M12x1.25	16	12.00	15.4
KI 16-DM16x1.5	16	M16x1.5	21	15.00	19.3
KI 20-D	20	M20x1.5	25	18.00	24.3
KI 25-D	25	M24x2	31	22.00	29.5
KI 30-DM27x2	30	M27x2	37	25.00	34.8
KI 35-D	35	M36x2	43	28.00	37.7
KI 40-D	40	M42x2	49	33.00	45.2
KI 50-D	50	M48x2	60	45.00	56.6

Special versions:

- **Version -DV:**
as standard, but housing heat-treated,
for static load capacity see **-V** load rating stat **C0**

Further versions are available on request. E.g.:
- Housing crack-tested
- Sliding face of inner ring hard chromium plated
- Special surface coating of housing

d ₂ max.	d ₄ ≈	d ₅	dk	h ₁	l ₃ min.	l ₄ ≈	W	Load rating static C ₀		Tilt angle α°	Weight kg
								Standard	-V		
mm	mm	mm	mm	mm	mm	mm	mm	kN	kN		
19	9.0	11	11.1	27	8	36.5	9	6	•	13	0.016
21	10.0	13	12.7	30	9	40.5	11	7	•	13	0.025
25	12.5	16	15.8	36	12	48.5	14	12	16	13	0.043
29	15.0	19	19.0	43	15	57.5	17	15	19	13	0.072
33	17.5	22	22.2	50	18	66.5	19	23	25	13	0.107
43	22.0	27	28.5	64	24	85.5	22	34	36	15	0.210
51	27.5	34	34.9	77	30	102.5	30	42	50	15	0.380
61	33.5	42	42.8	94	36	124.5	36	60	78	15	0.650
70	40.0	50	50.8	110	45	145.5	41	82	107	15	1.150
81	46.0	58	57.1	125	56	165.5	50	96	•	16	1.600
91	53.0	65	66.6	142	60	187.5	55	132	•	17	2.400
117	65.0	75	82.5	160	65	218.5	65	209	•	12	5.000

Mating materials:
Stainless steel on high-duty bronze
Maintenance required

Pneumatic stainless steel
 Special version for
 pneumatic cylinder

- Inner ring:** Stainless steel, hardened, ground and polished.
- Outer ring:** Swaged around the inner ring, sliding face made of high-duty bronze. Lubricant is distributed via the lubricating groove in the outer ring.
- Housing:** Stainless steel. The spherical bearing is pressed into the housing and caulked at both sides.

Lubrication nipple: Size 5 without lubricating nipple, sizes 6 to 50 lubricating nipple DIN 3405, shape D, further lubricating nipple shapes on request.

Female thread

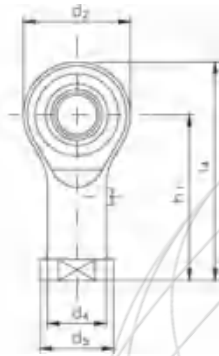
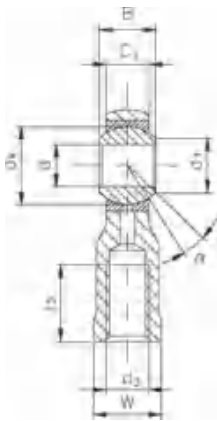

Designation	d	d ₃	B	C ₁	d ₁ ≈ mm
Righthand thread	mm	mm	mm	mm	mm
KI 5-NRM4	5	M4	8	6.00	7.7
KI 6-NR	6	M6	9	6.75	8.9
KI 8-NR	8	M8	12	9.00	10.3
KI 10-NRM10x1.25	10	M10x1.25	14	10.50	12.9
KI 12-NRM12x1.25	12	M12x1.25	16	12.00	15.4
KI 16-NRM16x1.5	16	M16x1.5	21	15.00	19.3
KI 20-NR	20	M20x1.5	25	18.00	24.3
KI 25-NR	25	M24x2	31	22.00	29.5
KI 30-NRM27x2	30	M27x2	37	25.00	34.8

Special versions:
- Version -R:

as standard, but inner ring hard chromium plated at sliding surface.

Further versions are available on request

d_2 max. mm	d_4 ≈ mm	d_5 mm	d_k mm	h_1 mm	l_3 min. mm	l_4 ≈ mm	W mm	Load rating static C_0 kN	Tilt angle α°	Weight kg
19	9.0	11	11.1	27	8	36.5	9	6	13	0.016
21	10.0	13	12.7	30	9	40.5	11	7	13	0.025
25	12.5	16	15.8	36	12	48.5	14	10	13	0.043
29	15.0	19	19.0	43	15	57.5	17	13	13	0.072
33	17.5	22	22.2	50	18	66.5	19	15	13	0.107
43	22.0	27	28.5	64	24	85.5	22	28	15	0.210
51	27.5	34	34.9	77	30	102.5	30	41	15	0.380
61	33.5	42	42.8	94	36	124.5	36	58	15	0.650
70	40.0	50	50.8	110	45	145.5	41	80	15	1.150

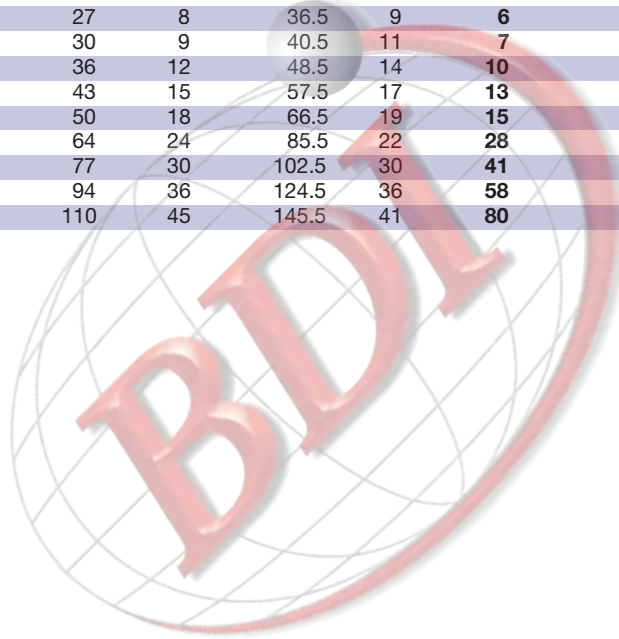

Mating materials:
Stainless steel on PTFE
Maintenance-free

Pneumatic stainless steel
 Special version for
 pneumatic cylinder

Inner ring: Stainless steel, hardened, ground and polished.

Outer ring: Brass lined with an antifriction film, consisting of PTFE, outer diameter ground.

Housing: Stainless steel. The spherical bearing is pressed into the housing and caulked at both sides.

Female thread

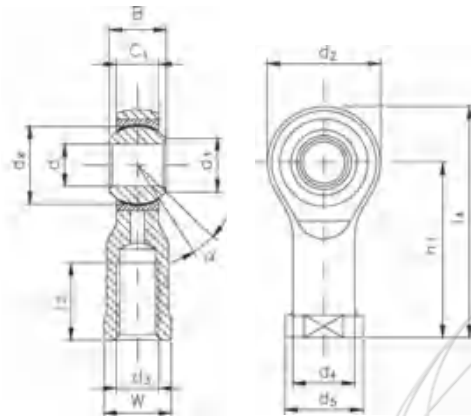

Designation	d	d ₃	B	C ₁	d ₁ ≈
Righthand thread	mm	mm	mm	mm	mm
KI 5-DNRM4	5	M4	8	6.00	7.7
KI 6-DNR	6	M6	9	6.75	8.9
KI 8-DNR	8	M8	12	9.00	10.3
KI 10-DNRM10x1.25	10	M10x1.25	14	10.50	12.9
KI 12-DNRM12x1.25	12	M12x1.25	16	12.00	15.4
KI 16-DNRM16x1.5	16	M16x1.5	21	15.00	19.3
KI 20-DNR	20	M20x1.5	25	18.00	24.3
KI 25-DNR	25	M24x2	31	22.00	29.5
KI 30-DNRM27x2	30	M27x2	37	25.00	34.8

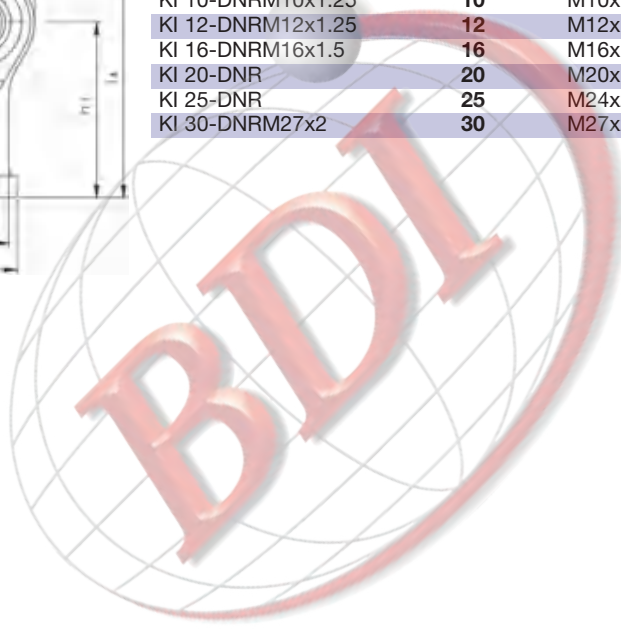



Special versions:
- Version -DR:

as standard, but inner ring hard chromium plated at sliding surface

Further versions are available on request

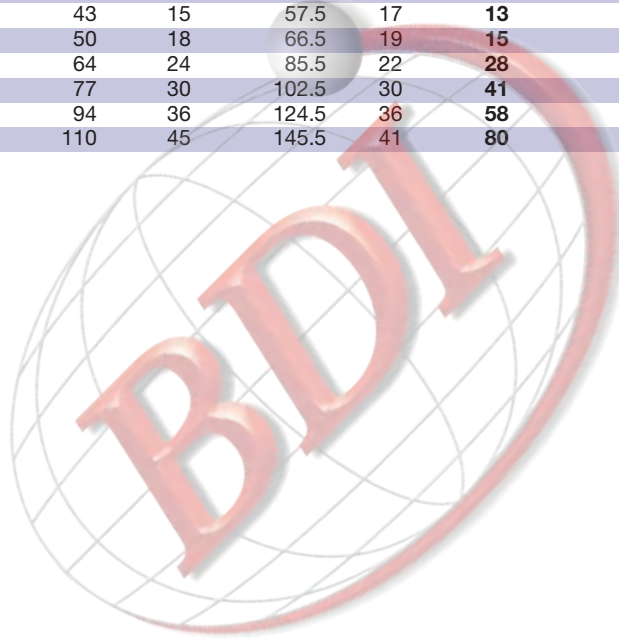
d ₂ max. mm	d ₄ ≈ mm	d ₅ mm	dk mm	h ₁ mm	l ₃ min. mm	l ₄ ≈ mm	W mm	Load rating static C ₀ kN	Tilt angle α°	Weight kg
19	9.0	11	11.1	27	8	36.5	9	6	13	0.016
21	10.0	13	12.7	30	9	40.5	11	7	13	0.025
25	12.5	16	15.8	36	12	48.5	14	10	13	0.043
29	15.0	19	19.0	43	15	57.5	17	13	13	0.072
33	17.5	22	22.2	50	18	66.5	19	15	13	0.107
43	22.0	27	28.5	64	24	85.5	22	28	15	0.210
51	27.5	34	34.9	77	30	102.5	30	41	15	0.380
61	33.5	42	42.8	94	36	124.5	36	58	15	0.650
70	40.0	50	50.8	110	45	145.5	41	80	15	1.150



Mating materials:
Stainless steel on PTFE
Maintenance-free

**Pneumatic stainless steel
copper alloys free**
Special version for
pneumatic cylinder

Inner ring: Stainless steel, hardened, ground and polished.

Outer ring: Stainless steel lined with an antifriction film, consisting of PTFE, cold formed around inner ring, outer diameter ground.

Housing: Stainless steel. The spherical bearing is pressed into the housing and caulked at both sides.

Female thread

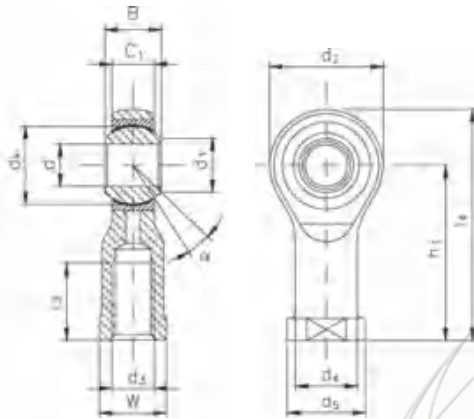

Designation	d	d ₃	B	C ₁	d ₁ ≈ mm
Righthand thread	mm	mm	mm	mm	mm
KI 5-DNRBFM4	5	M4	8	6.00	7.7
KI 6-DNRBF	6	M6	9	6.75	8.9
KI 8-DNRBF	8	M8	12	9.00	10.3
KI 10-DNRBFM10x1.25	10	M10x1.25	14	10.50	12.9
KI 12-DNRBFM12x1.25	12	M12x1.25	16	12.00	15.4
KI 16-DNRBFM16x1.5	16	M16x1.5	21	15.00	19.3
KI 20-DNRBF	20	M20x1.5	25	18.00	24.3
KI 25-DNRBF	25	M24x2	31	22.00	29.5
KI 30-DNRBFM27x2	30	M27x2	37	25.00	34.8

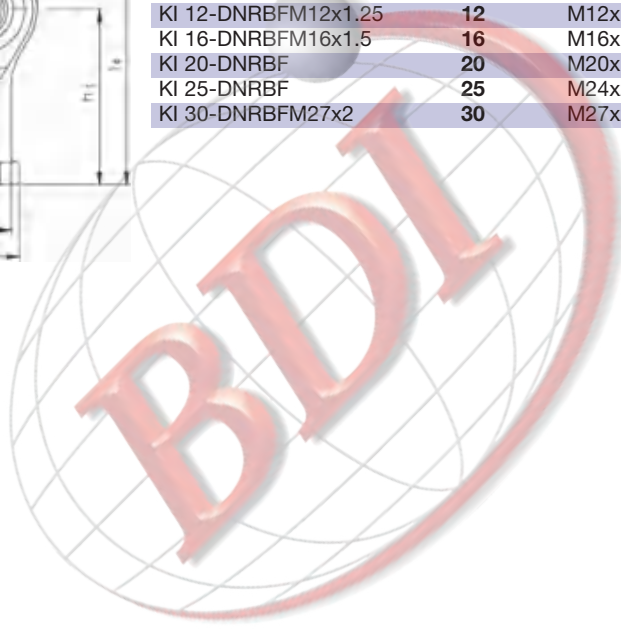



Special versions: available on request

d_2 max. mm	d_4 ≈ mm	d_5 mm	d_k mm	h_1 mm	l_3 min. mm	l_4 ≈ mm	W mm	Load rating static C_0 kN	Tilt angle α°	Weight kg
19	9.0	11	11.1	27	8	36.5	9	6	13	0.016
21	10.0	13	12.7	30	9	40.5	11	7	13	0.025
25	12.5	16	15.8	36	12	48.5	14	10	13	0.043
29	15.0	19	19.0	43	15	57.5	17	13	13	0.072
33	17.5	22	22.2	50	18	66.5	19	15	13	0.107
43	22.0	27	28.5	64	24	85.5	22	28	15	0.210
51	27.5	34	34.9	77	30	102.5	30	41	15	0.380
61	33.5	42	42.8	94	36	124.5	36	58	15	0.650
70	40.0	50	50.8	110	45	145.5	41	80	15	1.150

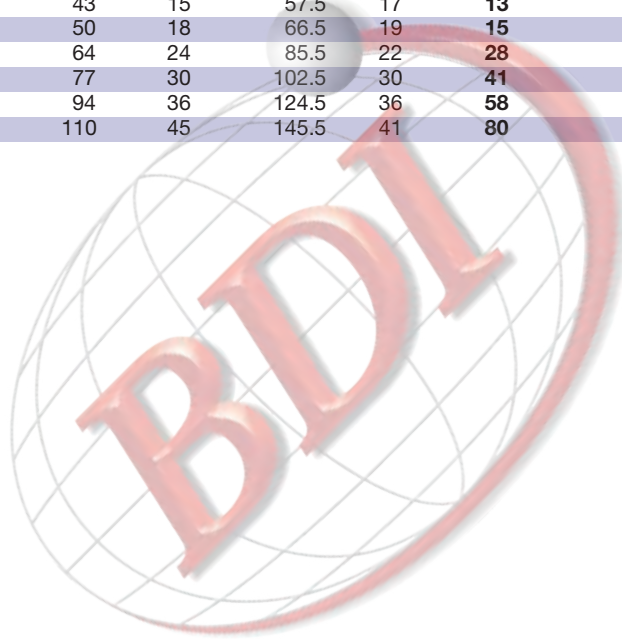

Ball bearing

Mounting sizes acc. to DIN ISO 12240-4 dimension series K

- Inner ring:** Antifriction bearing steel, hardened, high precision machined.
- Housing:** Steel with bearing outer ring pressed into housing, raceway precision ground.
- Rolling element:** Balls made from through-hardened, antifriction bearing steel.
- Covering disc:** Stainless steel plate caulked into housing.
- Lubrication:** The rod ends are given initial lubrication.
- Note:** With these rod ends, it is important to ensure that the tilt angle specified in the table is not exceeded, either while mounting or during operation, otherwise the cover washers may be damaged.

Female thread

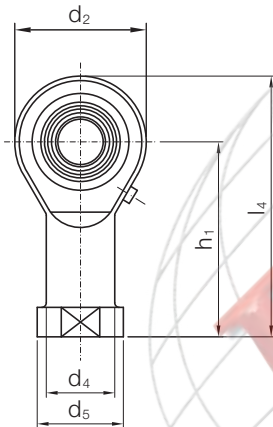
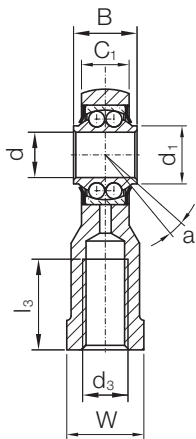

Designation		d	d ₃	B	C ₁	d ₁ ≈	d ₂
Righthand thread	Lefthand thread	mm	mm	mm	mm	mm	mm
KUI 6-ZZ	KUIL 6-ZZ	6	M6	9	6.75	8.0	21
KUI 8-ZZ	KUIL 8-ZZ	8	M8	12	9.00	10.0	25
KUI 10-ZZ	KUIL 10-ZZ	10	M10	14	10.50	12.4	29
KUI 12-ZZ	KUIL 12-ZZ	12	M12	16	12.00	14.6	33
KUI 14-ZZ	KUIL 14-ZZ	14	M14	19	13.50	16.4	37
KUI 16-ZZ	KUIL 16-ZZ	16	M16	21	15.00	18.7	43
KUI 18-ZZ	KUIL 18-ZZ	18	M18 x 1.5	23	16.50	22.0	47
KUI 20-ZZ	KUIL 20-ZZ	20	M20 x 1.5	25	18.00	24.0	51
KUI 22-ZZ	KUIL 22-ZZ	22	M22 x 1.5	28	20.00	26.0	55
KUI 25-ZZ	KUIL 25-ZZ	25	M24 x 2	31	22.00	29.8	61
KUI 30-ZZ	KUIL 30-ZZ	30	M30 x 2	37	25.00	35.6	71

Male thread

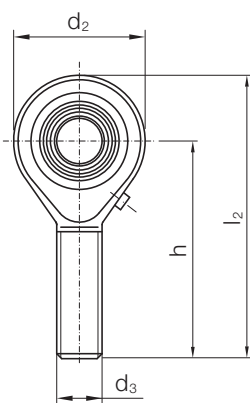
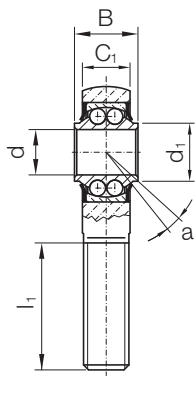

Designation		d	d ₃	B	C ₁	d ₁ ≈	d ₂
Righthand thread	Lefthand thread	mm	mm	mm	mm	mm	mm
KUA 6-ZZ	KUAL 6-ZZ	6	M6	9	6.75	8.0	21
KUA 8-ZZ	KUAL 8-ZZ	8	M8	12	9.00	10.0	25
KUA 10-ZZ	KUAL 10-ZZ	10	M10	14	10.50	12.4	29
KUA 12-ZZ	KUAL 12-ZZ	12	M12	16	12.00	14.6	33
KUA 14-ZZ	KUAL 14-ZZ	14	M14	14	13.50	16.4	37
KUA 16-ZZ	KUAL 16-ZZ	16	M16	21	15.00	18.7	43
KUA 18-ZZ	KUAL 18-ZZ	18	M18x1	23	16.50	22.0	47
KUA 20-ZZ	KUAL 20-ZZ	20	M20x1	25	18.00	24.0	51
KUA 22-ZZ	KUAL 22-ZZ	22	M22x1	28	20.00	26.0	55
KUA 25-ZZ	KUAL 25-ZZ	25	M24x2	31	22.00	29.8	61
KUA 30-ZZ	KUAL 30-ZZ	30	M30x2	37	25.00	35.6	71

Max. permissible speed:

This is affected by the bearing load, the bearing clearance, the lubricant and heat output and input. The maximum permissible speed given in the tables applies for a purely radial load, normal bearing clearance tolerance, no external heat, an operating temperature which is not above the limit, and a low and absolutely shock-free load.

Cabrivating nipple:

Size 6 to 10: DIN 3405
Size 12 to 30: DIN 71412

Load ratings:

calculated acc. to DIN ISO 76 and 281.

Special versions:

available on request

d_4 ≈	d_5	h_1	l_3 min.	l_4 ≈	W	Limiting speed	Load ratings bearing dynamic	Load ratings bearing static C_0	Tilt angle
mm	mm	mm	mm	mm	mm	min ⁻¹	kN	kN	α°
10.0	13.0	30	9	40.5	11	1300	1.83	0.36	7
12.5	16.0	36	12	48.5	14	1250	3.08	0.69	7
15.0	19.0	43	15	57.5	17	1200	3.91	0.94	7
17.5	22.0	50	18	66.5	19	1150	4.90	1.23	7
20.0	25.0	57	21	75.5	22	1000	5.00	1.36	7
22.0	27.0	64	24	85.5	22	950	5.20	1.55	7
25.0	31.0	71	27	94.5	27	850	6.49	1.97	7
27.5	34.0	77	30	102.5	30	800	6.70	2.17	7
30.0	37.0	84	33	111.5	32	725	7.23	2.39	7
32.5	42.0	94	36	124.5	36	550	10.90	3.05	7
40.0	50.8	110	45	145.5	41	425	14.88	5.01	7

h	l_1 min.	l_2 ≈	Limiting speed	Load ratings bearing dynamic C	Load ratings bearing static C_0	Tilt angle
mm	mm	mm	min ⁻¹	kN	kN	α°
36	21	46.5	1300	1.83	0.36	7
42	25	54.5	1250	3.08	0.69	7
48	28	62.5	1200	3.91	0.94	7
54	32	70.5	1150	4.90	1.23	7
60	36	78.5	1000	5.00	1.36	7
66	37	87.5	950	5.20	1.55	7
72	41	95.5	850	6.49	1.97	7
78	45	103.5	800	6.70	2.17	7
84	48	111.5	725	7.23	2.39	7
94	55	124.5	550	10.90	3.05	7
110	66	145.5	425	14.88	5.01	7

Roller bearing

Mounting sizes acc. to DIN ISO 12240-4 dimension series K

- Inner ring:** Antifriction bearing steel, hardened, high precision machined.
- Housing:** Steel with bearing outer ring pressed into housing, raceway precision ground.
- Rolling element:** Barrel roller bearings made from through-hardened, antifriction bearing steel.
- Retainer:** Synthetic material.
- Covering disc:** Stainless steel plate caulked into housing.
- Lubrication:** The rod ends are given initial lubrication.

Female thread

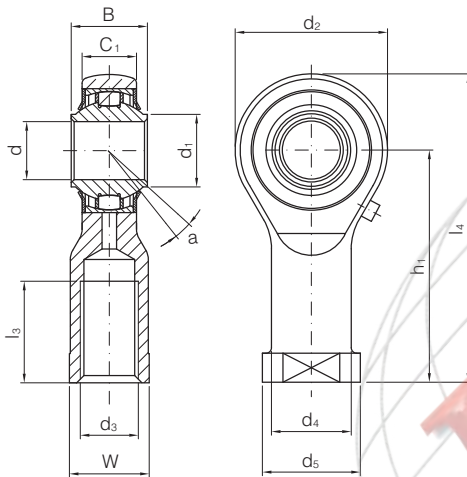

Designation		d	d ₃	B	C ₁	d ₁ ≈	d ₂ max.	d ₄
Righthand thread	Lefthand thread	mm	mm	mm	mm	mm	mm	mm
KI 20202-ZZ	KIL 20202-ZZ	12	M12	16	12	14.6	33	17.5
KI 20203-ZZ	KIL 20203-ZZ	16	M16	21	15	18.7	43	22.0
KI 20204-ZZ	KIL 20204-ZZ	20	M20x1.5	25	18	24.15	51	27.5
KI 20205-ZZ	KIL 20205-ZZ	25	M24x2	31	22	29.8	61	33.5
KI 20206-ZZ	KIL 20206-ZZ	30	M30x2	37	25	35.6	71	40.0

Male thread

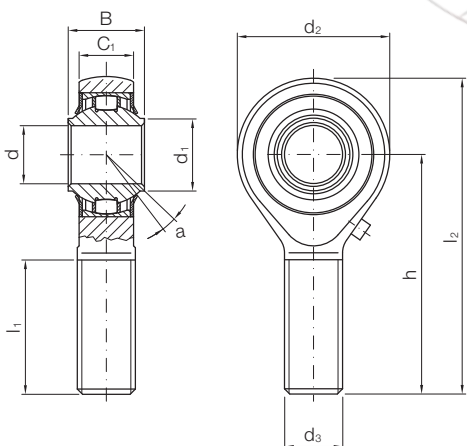

Designation		d	d ₃	B	C ₁	d ₁ ≈	d ₂ max.	h
Righthand thread	Lefthand thread	mm	mm	mm	mm	mm	mm	mm
KA 20202-ZZ	KAL 20202-ZZ	12	M12	16	12	14.6	33	54
KA 20203-ZZ	KAL 20203-ZZ	16	M16	21	15	18.7	43	66
KA 20204-ZZ	KAL 20204-ZZ	20	M20x1.5	25	18	24.15	51	78
KA 20205-ZZ	KAL 20205-ZZ	25	M24x2	31	22	29.8	61	94
KA 20206-ZZ	KAL 20206-ZZ	30	M30x2	37	25	35.6	71	110



Note: With these rod ends, it is important to ensure that the tilt angle specified in the table is not exceeded, either while mounting or during operation, otherwise the sealing washers may be damaged.

Max. permissible speed: This is affected by the bearing load, the bearing clearance, the lubricant and heat output and input. The maximum permissible speed given in the tables applies for a purely radial load, normal bearing clearance tolerance, no external heat, an operating temperature which is not above the limit, and a low and absolutely shock-free load.

Cabrivating nipple: DIN 71412

Load ratings: calculated acc. to DIN ISO 76 and 281

Special versions: full complement (without retainer) available on request

d ₅	h ₁	l ₃ min.	l ₄ ≈	W	Limiting speed	Load ratings		Tilt angle
						bearing dynamic C	bearing static C ₀	
mm	mm	mm	mm	mm	min ⁻¹	kN	kN	α°
22	50	18	66.5	19	950	9.55	7.70	7
27	64	24	85.5	22	650	9.55	8.10	7
34	77	30	103.5	30	550	14.99	13.40	7
42	94	36	124.5	36	400	23.12	21.85	5
50	110	45	145.5	41	300	28.82	26.20	7

l ₁ min.	l ₂ ≈	Limiting speed	Load ratings		Tilt angle
			bearing dynamic C	bearing static C ₀	
mm	mm	min ⁻¹	kN	kN	α°
32	70.5	950	9.55	7.70	7
37	87.5	650	9.55	8.10	7
45	104.5	550	14.90	13.40	7
55	124.5	400	23.12	21.85	5
66	145.5	300	28.82	26.20	7

Mating materials:
Steel on steel
Maintenance required

RS
 Special version
 adjustable clearance
 RS sealing

- Inner ring:** Antifriction bearing steel, hardened, ground and polished.
- Outer ring:** Made of heat-treated steel. Lubricant is distributed via the lubrication groove in the outer ring.
- Rubber bellows:** Synthetic rubber.
- Housing:** Sizes 8 to 12 free-cutting steel, sizes 14 to 30 tempering steel (standardised), all sizes galvanized and chromatised.
- Lubricating nipple:** DIN 3405, shape D, further lubricating nipple shapes available on request.
- Tolerances:** To DIN ISO 12240-4, schedule K, except: $d = H8$, $B = +0.3$

Note: With these rod ends, it is important to ensure that the tilt angle specified in the table is not exceeded, either while mounting or during operation, otherwise the rubber bellows may be damaged. Replacement for previous 2RS-version. Available on request.

Female thread

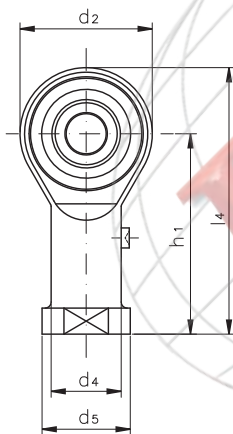
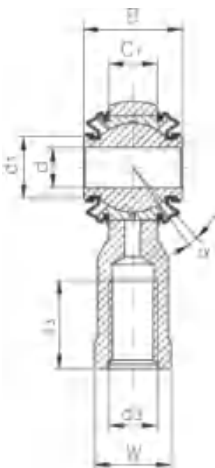

Designation		d	d ₃	B	C ₁	d ₁
Righthand thread	Lefthand thread	mm	mm	mm	mm	mm
KI 8-RS	KIL 8-RS	6	M8	19	9.0	11.00
KI 10-RS	KIL 10-RS	8	M10	21	10.5	13.00
KI 12-RS	KIL 12-RS	10	M12	23	12.0	15.50
KI 14-RS	KIL 14-RS	12	M14	26	13.5	17.00
KI 16-RS	KIL 16-RS	14	M16	28	15.0	19.50
KI 18-RS	KIL 18-RS	16	M18x1.5	30	16.5	22.00
KI 20-RS	KIL 20-RS	18	M20x1.5	32	18.0	24.50
KI 22-RS	KIL 22-RS	20	M22x1.5	35	20.0	26.50
KI 25-RS	KIL 25-RS	22	M24x2	38	22.0	29.50
KI 30-RS	KIL 30-RS	25	M30x2	44	25.0	35.00

Male thread

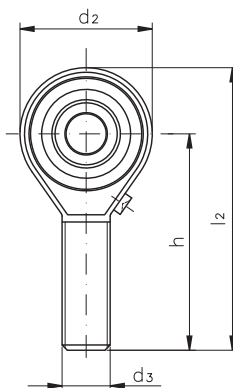
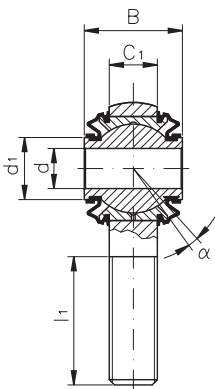

Designation		d	d ₃	B	C ₁	d ₁
Righthand thread	Lefthand thread	mm	mm	mm	mm	mm
KA 8-RS	KAL 8-RS	6	M8	19	9.0	11.00
KA 10-RS	KAL 10-RS	8	M10	21	10.5	13.00
KA 12-RS	KAL 12-RS	10	M12	23	12.0	15.50
KA 14-RS	KAL 14-RS	12	M14	26	13.5	17.00
KA 16-RS	KAL 16-RS	14	M16	28	15.0	19.50
KA 18-RS	KAL 18-RS	16	M18x1.5	30	16.5	22.00
KA 20-RS	KAL 20-RS	18	M20x1.5	32	18.0	24.50
KA 22-RS	KAL 22-RS	20	M22x1.5	35	20.0	26.50
KA 25-RS	KAL 25-RS	22	M24x2	38	22.0	29.50
KA 30-RS	KAL 30-RS	25	M30x2	44	25.0	35.00

Special versions:

- Mating materials steel on high-duty bronze.
 - Mating materials steel on steel with anti-friction coating.
- Further versions are available on request.

d ₂ max. mm	d ₄ mm	d ₅ mm	h ₁ mm	l ₃ min. mm	l ₄ ≈ mm	W mm	Load rating static C ₀ kN	Tilt angle α°	Weight kg
25	12.5	16	36	12	48.5	14	12	9	0.066
29	15.0	19	43	15	57.5	17	15	9	0.118
33	17.5	22	50	18	66.5	19	23	9	0.162
37	20.0	25	57	21	75.5	22	24	10	0.235
43	22.0	27	64	24	85.5	22	34	10	0.285
47	25.0	31	71	27	94.5	27	39	10	0.385
51	27.5	34	77	30	102.5	30	42	10	0.500
55	30.0	37	84	33	111.5	32	54	10	0.615
61	33.5	42	94	36	124.5	36	60	10	0.800
71	40.0	50	110	45	145.5	41	82	12	1.210

d ₂ max. mm	hmm	l ₁ min. mm	l ₂ ≈ mm	Load rating static C ₀ kN	Tilt angle α°	Weight kg
25	42	25	54.5	8	9	0.055
29	48	28	62.5	13	9	0.100
33	54	32	70.5	21	9	0.140
37	60	36	78.5	22	10	0.200
43	66	37	87.5	33	10	0.260
47	72	41	95.5	39	10	0.350
51	78	45	103.5	42	10	0.460
55	84	48	111.5	54	10	0.560
61	94	55	124.5	60	10	0.740
71	110	66	145.5	82	12	1.120

Mating materials:
Steel on PTFE
Maintenance-free

RS
Special version
RS sealing

- Inner ring:** Antifriction bearing steel, hardened, ground and polished.
- Outer ring:** Steel lined with an antifriction film, consisting PTFE.
- Rubber bellows:** Synthetic rubber.
- Housing:** Sizes 8 to 12 free-cutting steel, sizes 14 to 30 tempering steel (standardised), all sizes galvanized and chromatised.
- Tolerances:** Acc. To DIN ISO 12240-4, schedule K, except: $d = H8$, $B = \pm 0.3$
- Note:** With these rod ends, it is important to ensure that the tilt angle specified in the table is not exceeded, either while mounting or during operation, otherwise the rubber bellows may be damaged. Replacement for previous 2RS-version. Available on request.

Female thread

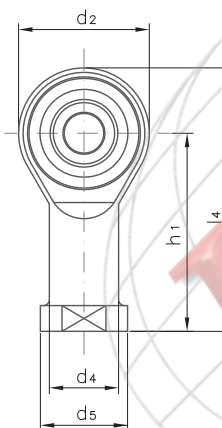
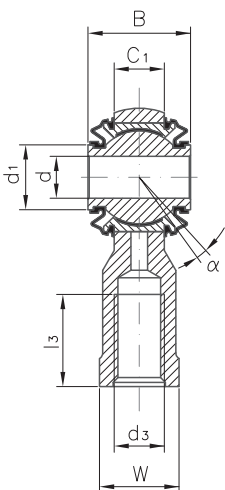

Designation		d	d ₃	B	C ₁	d ₁
Righthand thread	Lefthand thread	mm	mm	mm	mm	mm
KI 8-DRS	KIL 8-DRS	6	M8	19	9.0	11.0
KI 10-DRS	KIL 10-DRS	8	M10	21	10.5	13.0
KI 12-DRS	KIL 12-DRS	10	M12	23	12.0	15.5
KI 14-DRS	KIL 14-DRS	12	M14	26	13.5	17.0
KI 16-DRS	KIL 16-DRS	14	M16	28	15.0	19.5
KI 18-DRS	KIL 18-DRS	16	M18x1.5	30	16.5	22.0
KI 20-DRS	KIL 20-DRS	18	M20x1.5	32	18.0	24.5
KI 22-DRS	KIL 22-DRS	20	M22x1.5	35	20.0	26.5
KI 25-DRS	KIL 25-DRS	22	M24x2	38	22.0	29.5
KI 30-DRS	KIL 30-DRS	25	M30x2	44	25.0	35.0

Male thread

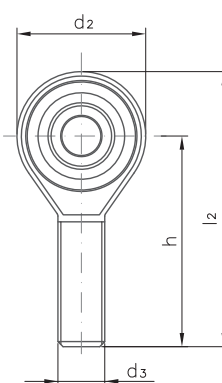
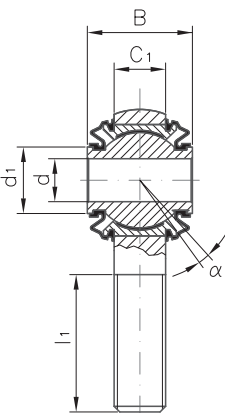

Designation		d	d ₃	B	C ₁	d ₁
Righthand thread	Lefthand thread	mm	mm	mm	mm	mm
KA 8-DRS	KAL 8-DRS	6	M8	19	9.0	11.0
KA 10-DRS	KAL 10-DRS	8	M10	21	10.5	13.0
KA 12-DRS	KAL 12-DRS	10	M12	23	12.0	15.5
KA 14-DRS	KAL 14-DRS	12	M14	26	13.5	17.0
KA 16-DRS	KAL 16-DRS	14	M16	28	15.0	19.5
KA 18-DRS	KAL 18-DRS	16	M18x1.5	30	16.5	22.0
KA 20-DRS	KAL 20-DRS	18	M20x1.5	32	18.0	24.5
KA 22-DRS	KAL 22-DRS	20	M22x1.5	35	20.0	26.5
KA 25-DRS	KAL 25-DRS	22	M24x2	38	22.0	29.5
KA 30-DRS	KAL 30-DRS	25	M30x2	44	25.0	35.0



Special versions: available on request

d ₂ max. mm	d ₄ mm	d ₅ mm	h ₁ mm	l ₃ min. mm	l ₄ ≈ mm	W mm	Load rating static C ₀ kN	Tilt angle α°	Weight kg
25	12.5	16	36	12	48.5	14	12	9	0.066
29	15.0	19	43	15	57.5	17	15	9	0.118
33	17.5	22	50	18	66.5	19	23	9	0.162
37	20.0	25	57	21	75.5	22	24	10	0.235
43	22.0	27	64	24	85.5	22	34	10	0.285
47	25.0	31	71	27	94.5	27	39	10	0.385
51	27.5	34	77	30	102.5	30	42	10	0.500
55	30.0	37	84	33	111.5	32	54	10	0.615
61	33.5	42	94	36	124.5	36	60	10	0.800
71	40.0	50	110	45	145.5	41	82	12	1.210

d ₂ max. mm	h mm	l ₁ min. mm	l ₂ ≈ mm	Load rating static C ₀ kN	Tilt angle α°	Weight kg
25	42	25	54.5	10	9	0.055
29	48	28	62.5	15	9	0.100
33	54	32	70.5	23	9	0.140
37	60	36	78.5	24	10	0.200
43	66	37	87.5	33	10	0.260
47	72	41	95.5	39	10	0.350
51	78	45	103.5	42	10	0.460
55	84	48	111.5	54	10	0.560
61	94	55	124.5	60	10	0.740
71	110	66	145.5	82	12	1.120

Mating materials:
Steel on heavy-duty bronze
Maintenance required

Type G
 DIN ISO 12240-1
 dimension series K

- Inner ring:** Antifriction bearing steel, hardened, ground and polished.
- Outer ring:** Outer diameter ground. Sliding face made of high-duty bronze. Lubricant is distributed via the lubricating groove in the outer ring.
- Lubrication:** The lubricant enters the lubricating groove through a cross hole in the outer ring.
- Special versions:** are available on request e.g.:
 - Sliding face of inner ring hard chromium plated.

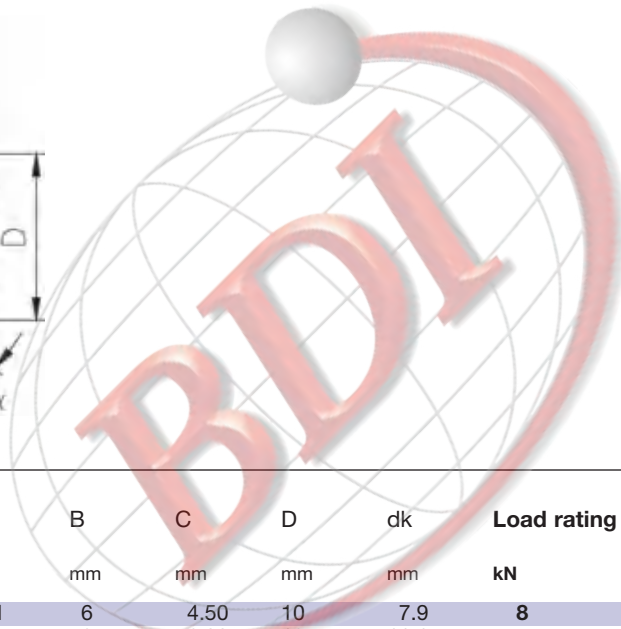
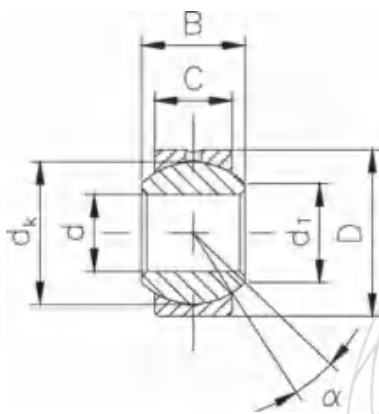

Designation	d	d ₁	B	C	D	dk	Load rating static C ₀	Tilt angle	Weight
	mm	≈ mm	mm	mm	mm	mm	kN	α°	kg
G 3	3	5.1	6	4.50	10	7.9	8	13	0.004
G 5	5	7.7	8	6.00	13	11.1	15	13	0.007
G 6	6	8.9	9	6.75	16	12.7	19	13	0.010
G 8	8	10.3	12	9.00	19	15.8	31	13	0.016
G 10	10	12.9	14	10.50	22	19.0	43	13	0.031
G 12	12	15.4	16	12.00	26	22.2	58	13	0.065
G 14	14	16.8	19	13.50	28	25.4	74	15	0.090
G 16	16	19.3	21	15.00	32	28.5	92	15	0.100
G 18	18	21.8	23	16.50	35	31.7	112	15	0.125
G 20	20	24.3	25	18.00	40	34.9	135	15	0.180
G 22	22	25.8	28	20.00	42	38.1	164	15	0.210
G 25	25	29.5	31	22.00	47	42.8	203	15	0.295
G 30	30	34.8	37	25.00	55	50.8	273	15	0.425
G 35	35	37.7*	43	28.00*	62*	57.1	344	16	0.500
G 40	40	45.2*	49	33.00*	75*	66.6	473	17	0.900
G 50	50	56.6*	60	45.00	90	82.5	798	12	1.640

*) deviates from standard

Mating materials:
Steel on heavy-duty bronze
Maintenance required

Type S
Special version

- Inner ring:** Antifriction bearing steel, hardened, ground and polished.
- Outer ring:** Outer diameter ground. Sliding face made of high-duty bronze. Lubricant is distributed via the lubricating groove in the outer ring.
- Outer case:** Free-cutting steel, outer diameter ground. Spherical bearing is pressed into the outer case and secured at both sides against axial movement. However the two outer rings should be axial supported at mounting.
- Lubrication:** The lubricant enters the lubricating groove through a cross hole in the outer case.
- Special versions:** are available on request e.g.:
 - Sliding face of inner ring hard chromium plated.
 - Outer case made of stainless steel.

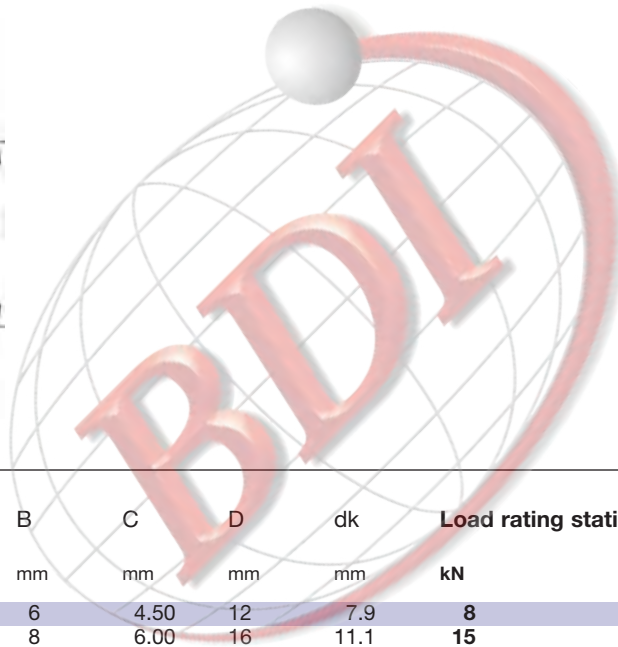
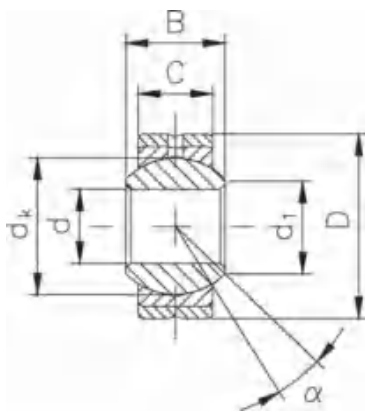

Designation	d	d ₁	B	C	D	dk	Load rating static C ₀	Tilt angle	Weight
	mm	mm	mm	mm	mm	mm	kN	α°	kg
S 3	3	5.1	6	4.50	12	7.9	8	13	0.005
S 5	5	7.7	8	6.00	16	11.1	15	13	0.009
S 6	6	8.9	9	6.75	18	12.7	19	13	0.013
S 8	8	10.3	12	9.00	22	15.8	31	13	0.024
S 10	10	12.9	14	10.50	26	19.0	43	13	0.040
S 12	12	15.4	16	12.00	30	22.2	58	13	0.080
S 14	14	16.8	19	13.50	34	25.4	74	15	0.100
S 16	16	19.3	21	15.00	38	28.5	92	15	0.130
S 18	18	21.8	23	16.50	42	31.7	112	15	0.170
S 20	20	24.3	25	18.00	46	34.9	135	15	0.230
S 22	22	25.8	28	20.00	50	38.1	164	15	0.280
S 25	25	29.5	31	22.00	56	42.8	203	15	0.390
S 30	30	34.8	37	25.00	66	50.8	273	15	0.610

Mating materials:
Steel on PTFE
Maintenance-free

Type G
 DIN ISO 12240-1
 dimension series K

Inner ring: Antifriction bearing steel, hardened, ground and polished.

Outer ring: Steel lined with an antifriction film, consisting of PTFE, outer diameter ground.

Special versions: are available on request e.g.:
 - Sliding face of inner ring hard chromium plated.

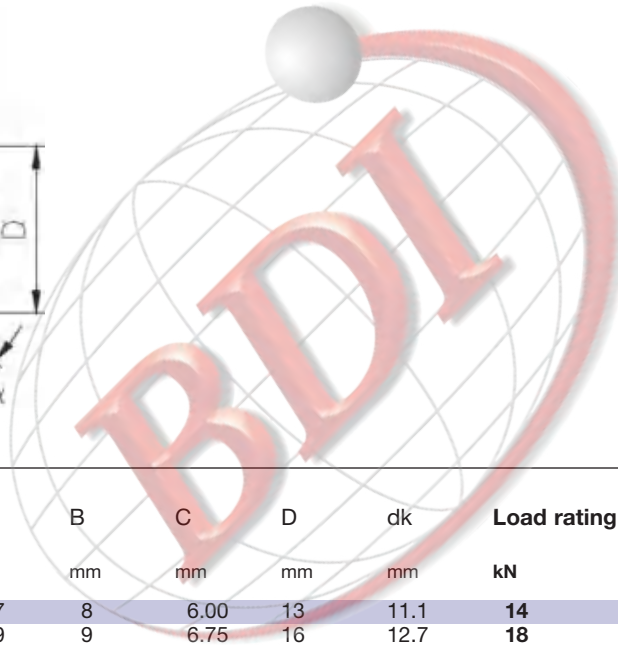
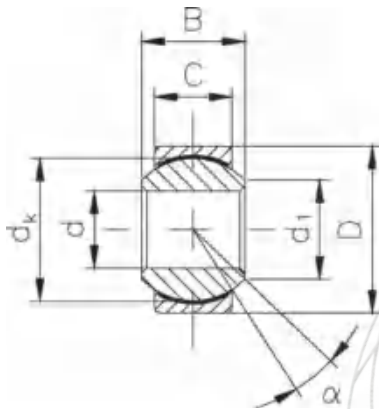

Designation	d	d ₁	B	C	D	dk	Load rating static C ₀	Tilt angle	Weight
	mm	≈ mm	mm	mm	mm	mm	kN	°	kg
G 5-D	5	7.7	8	6.00	13	11.1	14	13	0.007
G 6-D	6	8.9	9	6.75	16	12.7	18	13	0.010
G 8-D	8	10.3	12	9.00	19	15.8	30	13	0.016
G 10-D	10	12.9	14	10.50	22	19.0	42	13	0.031
G 12-D	12	15.4	16	12.00	26	22.2	56	13	0.065
G 14-D	14	16.8	19	13.50	28	25.4	72	15	0.090
G 16-D	16	19.3	21	15.00	32	28.5	90	15	0.100
G 18-D	18	21.8	23	16.50	35	31.7	110	15	0.125
G 20-D	20	24.3	25	18.00	40	34.9	132	15	0.180
G 22-D	22	25.8	28	20.00	42	38.1	160	15	0.210
G 25-D	25	29.5	31	22.00	47	42.8	198	15	0.295
G 30-D	30	34.8	37	25.00	55	50.8	267	15	0.425
G 35-D	35	37.7*	43	28.00*	62*	57.1	336	16	0.500
G 40-D	40	45.2*	49	33.00*	75*	66.6	462	17	0.900
G 50-D	50	56.6*	60	45.00	90	82.5	780	12	1.640

*) deviates from standard

Mating materials:
Steel on PTFE
Maintenance-free

Type S
Special version

- Inner ring:** Antifriction bearing steel, hardened, ground and polished.
- Outer ring:** Steel lined with an antifriction film, consisting of PTFE, outer diameter ground.
- Outer case:** Free-cutting steel, outer diameter ground. Spherical bearing is pressed into the outer case and secured at both sides against axial movement.
- Special versions:** are available on request e.g.:
 - Sliding face of inner ring hard chromium plated.
 - Outer case made of stainless steel.

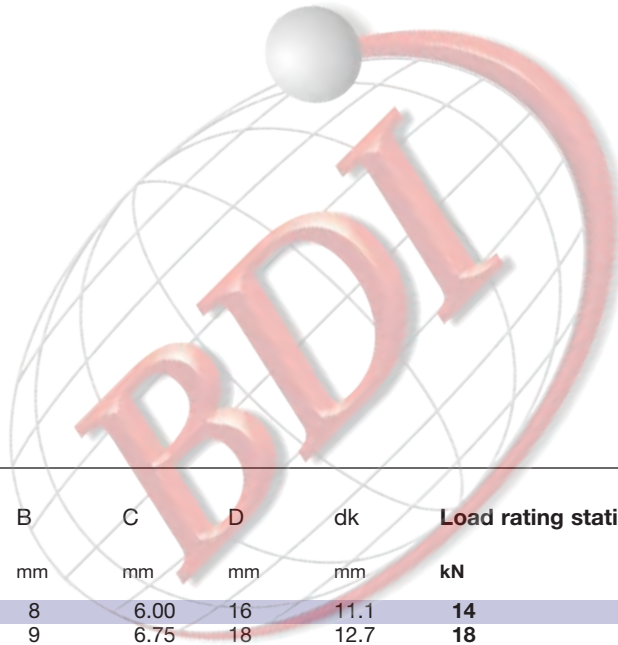
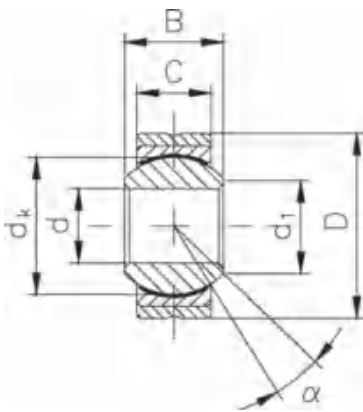

Designation	d	d ₁	B	C	D	dk	Load rating static C ₀	Tilt angle	Weight
	mm	mm	mm	mm	mm	mm	kN	°	kg
S 5-D	5	7.7	8	6.00	16	11.1	14	13	0.009
S 6-D	6	8.9	9	6.75	18	12.7	18	13	0.013
S 8-D	8	10.3	12	9.00	22	15.8	30	13	0.024
S 10-D	10	12.9	14	10.50	26	19.0	42	13	0.040
S 12-D	12	15.4	16	12.00	30	22.2	56	13	0.080
S 14-D	14	16.8	19	13.50	34	25.4	72	15	0.110
S 16-D	16	19.3	21	15.00	38	28.5	90	15	0.130
S 18-D	18	21.8	23	16.50	42	31.7	110	15	0.170
S 20-D	20	24.3	25	18.00	46	34.9	132	15	0.230
S 22-D	22	25.8	28	20.00	50	38.1	160	15	0.280
S 25-D	25	29.5	31	22.00	56	42.8	198	15	0.390
S 30-D	30	34.8	37	25.00	66	50.8	267	15	0.610

Mating materials:
Stainless steel on
heavy-duty bronze
Maintenance required

Stainless steel
 Type G
 DIN ISO 12240-1
 dimension series K

Inner ring: Stainless steel, hardened, ground and polished.

Outer ring: Outer diameter ground. Sliding face made of high-duty bronze. Lubricant is distributed via the lubricating groove in the outer ring.

Lubrication: The lubricant enters the lubricating groove through a cross hole in the outer ring.

Special versions: - **Version -R:** as standard, but inner ring hard chromium plated at sliding surface.
 Further versions are available on request.

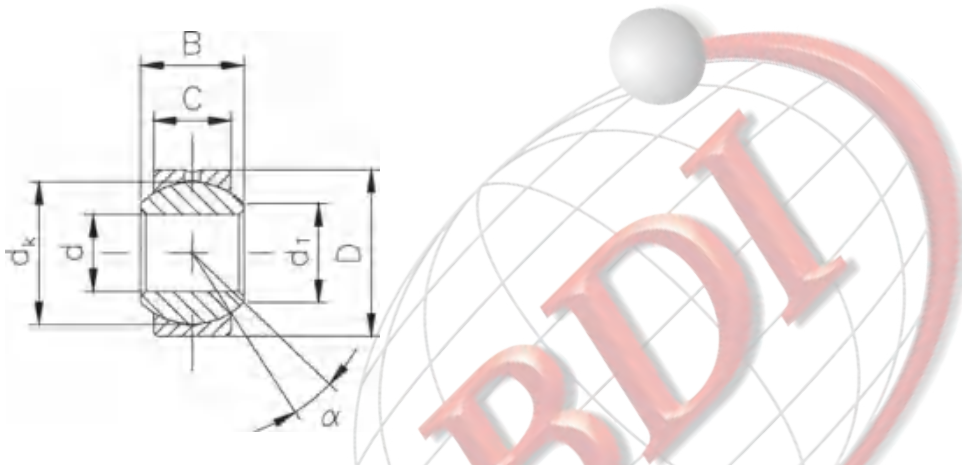

Designation	d	d ₁	B	C	D	dk	Load rating static C ₀	Tilt angle	Weight
	mm	≈ mm	mm	mm	mm	mm	kN	°	kg
G 5-NR	5	7.7	8	6.00	13	11.1	15	13	0.007
G 6-NR	6	8.9	9	6.75	16	12.7	19	13	0.010
G 8-NR	8	10.3	12	9.00	19	15.8	31	13	0.016
G 10-NR	10	12.9	14	10.50	22	19.0	43	13	0.031
G 12-NR	12	15.4	16	12.00	26	22.2	58	13	0.065
G 14-NR	14	16.8	19	13.50	28	25.4	74	15	0.090
G 16-NR	16	19.3	21	15.00	32	28.5	92	15	0.100
G 18-NR	18	21.8	23	16.50	35	31.7	112	15	0.125
G 20-NR	20	24.3	25	18.00	40	34.9	135	15	0.180
G 22-NR	22	25.8	28	20.00	42	38.1	164	15	0.210
G 25-NR	25	29.5	31	22.00	47	42.8	203	15	0.295
G 30-NR	30	34.8	37	25.00	55	50.8	273	15	0.425

Gleitpaarung:
Stahl auf Hochleistungsbronze
wartungspflichtig

Stainless steel
Special version type S

- Inner ring:** Stainless steel, hardened, ground and polished.
- Outer ring:** Outer diameter ground. Sliding face made of high-duty bronze. Lubricant is distributed via the lubricating groove in the outer ring.
- Outer case:** Stainless steel, outer diameter ground. Spherical bearing is pressed into the outer case and secured at both sides against axial movement.
- Lubrication:** The lubricant enters the lubricating groove through a cross hole in the outer case.
- Special versions:** - **Version -R:**
 as standard, but inner ring hard chromium plated at sliding surface.
 Further versions are available on request.

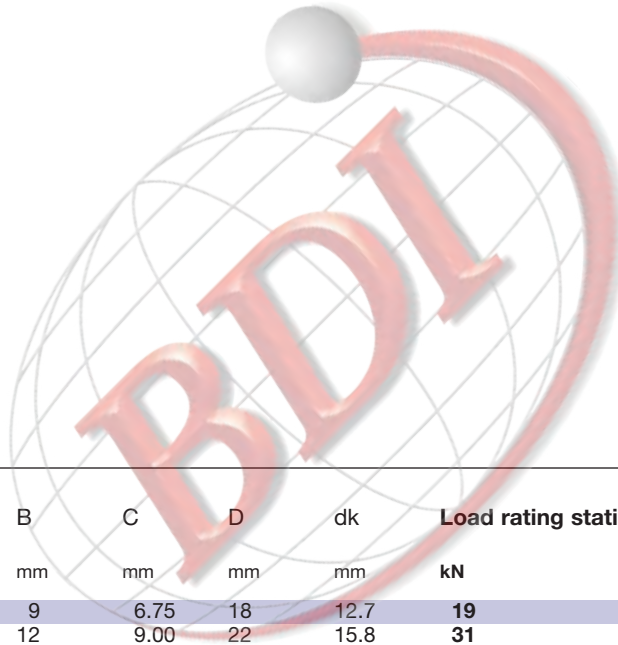
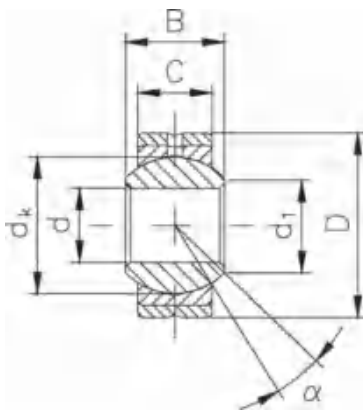

Designation	d	d ₁	B	C	D	dk	Load rating static C ₀	Tilt angle	Weight
	mm	mm	mm	mm	mm	mm	kN	α°	kg
S 6-NR	6	8.9	9	6.75	18	12.7	19	13	0.013
S 8-NR	8	10.3	12	9.00	22	15.8	31	13	0.024
S 10-NR	10	12.9	14	10.50	26	19.0	43	13	0.040
S 12-NR	12	15.4	16	12.00	30	22.2	58	13	0.080
S 14-NR	14	16.8	19	13.50	34	25.4	74	15	0.110
S 16-NR	16	19.3	21	15.00	38	28.5	92	15	0.130
S 18-NR	18	21.8	23	16.50	42	31.7	131	15	0.170
S 20-NR	20	24.3	25	18.00	46	34.9	157	15	0.230
S 22-NR	22	25.8	28	20.00	50	38.1	164	15	0.280
S 25-NR	25	29.5	31	22.00	56	42.8	203	15	0.390
S 30-NR	30	34.8	37	25.00	66	50.8	273	15	0.610

Mating materials:
Stainless steel on PTFE
Maintenance-free

Stainless steel
 Type G
 DIN ISO 12240-1
 dimension series K

Inner ring: Stainless steel, hardened, ground and polished.

Outer ring: Steel lined with an antifriction film, consisting of PTFE, outer diameter ground.

Special versions: - **Version -DR:**
 as standard, but inner ring hard chromium plated at sliding surface.
 Further versions are available on request.

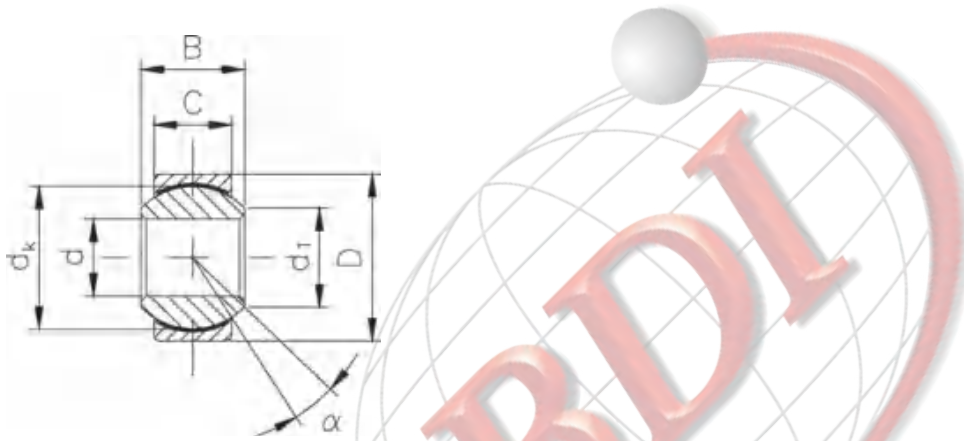

Designation	d	d ₁	B	C	D	dk	Load rating static C ₀	Tilt angle	Weight
	mm	≈ mm	mm	mm	mm	mm	kN	α°	kg
G 5-DNR	5	7.7	8	6.00	13	11.1	14	13	0.007
G 6-DNR	6	8.9	9	6.75	16	12.7	18	13	0.010
G 8-DNR	8	10.3	12	9.00	19	15.8	30	13	0.016
G 10-DNR	10	12.9	14	10.50	22	19.0	42	13	0.031
G 12-DNR	12	15.4	16	12.00	26	22.2	56	13	0.065
G 14-DNR	14	16.8	19	13.50	28	25.4	72	15	0.090
G 16-DNR	16	19.3	21	15.00	32	28.5	90	15	0.100
G 18-DNR	18	21.8	23	16.50	35	31.7	110	15	0.125
G 20-DNR	20	24.3	25	18.00	40	34.9	132	15	0.180
G 22-DNR	22	25.8	28	20.00	42	38.1	160	15	0.210
G 25-DNR	25	29.5	31	22.00	47	42.8	198	15	0.295
G 30-DNR	30	34.8	37	25.00	55	50.8	267	15	0.425

Mating materials:
Stainless steel on PTFE
Maintenance-free

Stainless steel
Special version type S

- Inner ring:** Stainless steel, hardened, ground and polished.
- Outer ring:** Steel lined with an antifriction film, consisting of PTFE, cold formed around inner ring, outside diameter ground.
- Outer case:** Stainless steel, outer diameter ground. Spherical bearing is pressed into the outer case and secured at both sides against axial movement.
- Special versions:** - **Version -DR:**
 as standard, but inner ring hard chromium plated at sliding surface.
 Further versions are available on request.

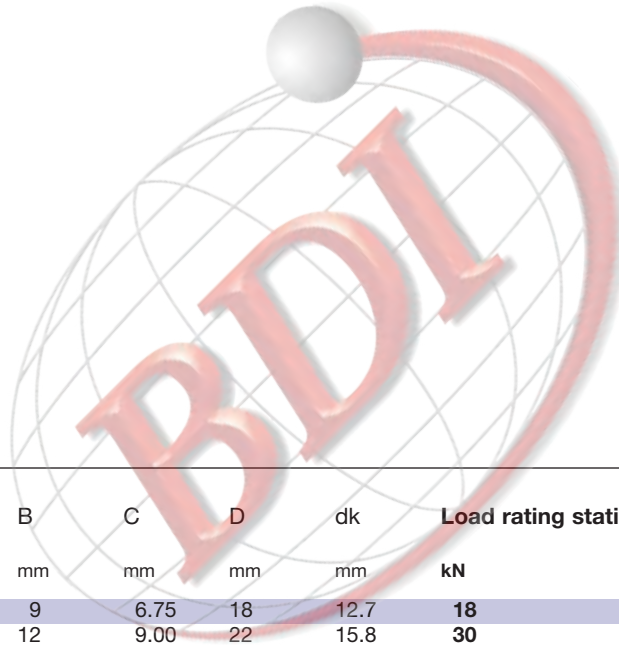
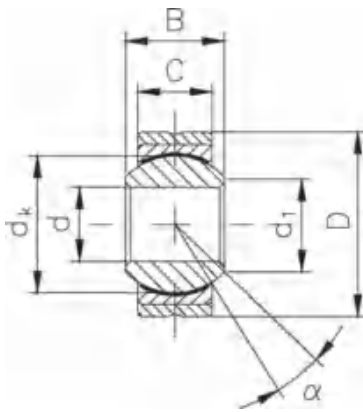

Designation	d	d ₁	B	C	D	dk	Load rating static C ₀	Tilt angle	Weight
	mm	mm	mm	mm	mm	mm	kN	α°	kg
S 6-DNR	6	8.9	9	6.75	18	12.7	18	13	0.013
S 8-DNR	8	10.3	12	9.00	22	15.8	30	13	0.024
S 10-DNR	10	12.9	14	10.50	26	19.0	42	13	0.040
S 12-DNR	12	15.4	16	12.00	30	22.2	56	13	0.080
S 14-DNR	14	16.8	19	13.50	34	25.4	72	15	0.110
S 16-DNR	16	19.3	21	15.00	38	28.5	90	15	0.130
S 18-DNR	18	21.8	23	16.50	42	31.7	110	15	0.170
S 20-DNR	20	24.3	25	18.00	46	34.9	132	15	0.230
S 22-DNR	22	25.8	28	20.00	50	38.1	160	15	0.280
S 25-DNR	25	29.5	31	22.00	56	42.8	198	15	0.390
S 30-DNR	30	34.8	37	25.00	66	50.8	267	15	0.610

Mating materials:
Stainless steel on PTFE
Maintenance-free

**Stainless steel
copper alloys free**
Type G
DIN ISO 12240-1
dimension series K

Inner ring: Stainless steel, hardened, ground and polished.
Outer ring: Stainless steel lined with an antifriction film, consisting of PTFE, outer diameter ground.
Special versions: are available on request.

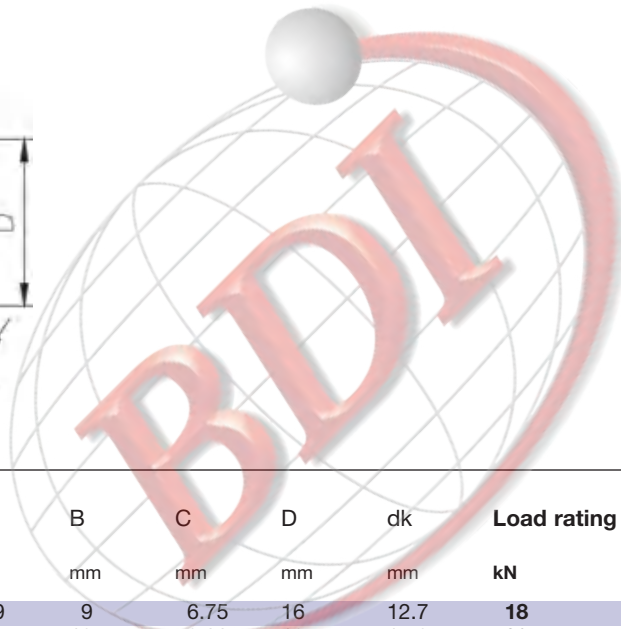
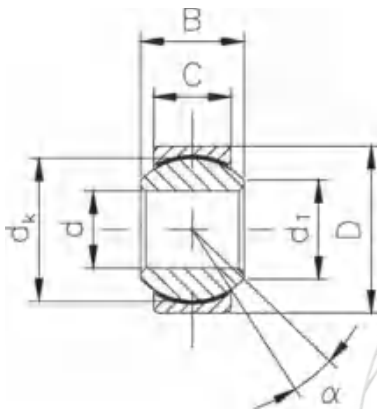

Designation	d	d ₁ ≈ mm	B	C	D	dk	Load rating static C ₀ kN	Tilt angle α°	Weight kg
G 6-DNRBF	6	8.9	9	6.75	16	12.7	18	13	0.010
G 8-DNRBF	8	10.3	12	9.00	19	15.8	30	13	0.016
G 10-DNRBF	10	12.9	14	10.50	22	19.0	42	13	0.031
G 12-DNRBF	12	15.4	16	12.00	26	22.2	56	13	0.065
G 14-DNRBF	14	16.8	19	13.50	28	25.4	72	15	0.090
G 16-DNRBF	16	19.3	21	15.00	32	28.5	90	15	0.100
G 18-DNRBF	18	21.8	23	16.50	35	31.7	110	15	0.125
G 20-DNRBF	20	24.3	25	18.00	40	34.9	132	15	0.180
G 22-DNRBF	22	25.8	28	20.00	42	38.1	160	15	0.210
G 25-DNRBF	25	29.5	31	22.00	47	42.8	198	15	0.295
G 30-DNRBF	30	34.8	37	25.00	55	50.8	267	15	0.425

Mating materials:
Stainless steel on PTFE
Maintenance-free

Stainless steel
copper alloys free
Special version type S

Inner ring: Stainless steel, hardened, ground and polished.

Outer ring: Stainless steel lined with an antifriction film, consisting of PTFE, outer diameter ground.

Outer case: Stainless steel, outer diameter ground. Spherical bearing is pressed into the outer case and secured at both sides against axial movement.

Special versions: are available on request.

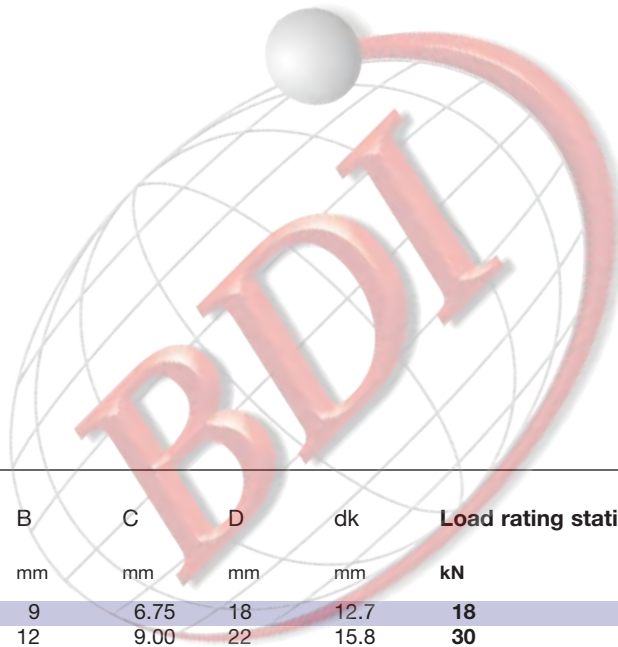
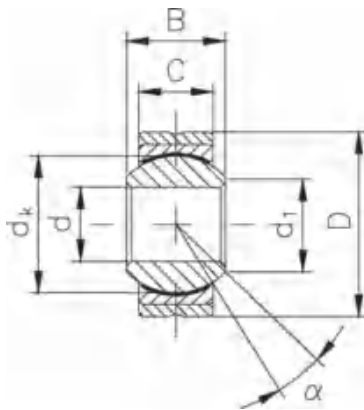

Designation	d	d ₁	B	C	D	dk	Load rating static C ₀	Tilt angle	Weight
	mm	mm	mm	mm	mm	mm	kN	α°	kg
S 6-DNRBF	6	8.9	9	6.75	18	12.7	18	13	0.013
S 8-DNRBF	8	10.3	12	9.00	22	15.8	30	13	0.024
S 10-DNRBF	10	12.9	14	10.50	26	19.0	42	13	0.040
S 12-DNRBF	12	15.4	16	12.00	30	22.2	56	13	0.080
S 14-DNRBF	14	16.8	19	13.50	34	25.4	72	15	0.110
S 16-DNRBF	16	19.3	21	15.00	38	28.5	90	15	0.130
S 18-DNRBF	18	21.8	23	16.50	42	31.7	110	15	0.170
S 20-DNRBF	20	24.3	25	18.00	46	34.9	132	15	0.230
S 22-DNRBF	22	25.8	28	20.00	50	38.1	160	15	0.280
S 25-DNRBF	25	29.5	31	22.00	56	42.8	198	15	0.390
S 30-DNRBF	30	34.8	37	25.00	66	50.8	267	15	0.610

Mating materials:
Steel on steel
Maintenance required

RS
Special version
2RS sealing

- Inner ring:** Antifriction bearing steel, hardened, ground and polished.
- Outer ring:** Made of heat-treated steel. Lubricant is distributed via the lubrication groove in the outer ring.
- Rubber bellows:** Synthetic rubber.
- Lubrication:** The lubricant enters the lubricating groove through a cross hole in the outer ring.
- Tolerances:** To DIN ISO 12240-1, schedule K, except: $d = H8$, $B = +0.3$

Note: With these rod ends, it is important to ensure that the tilt angle specified in the table is not exceeded, either while mounting or during operation, otherwise the rubber bellows may be damaged. Replacement for previous 2RS-version. Available on request.

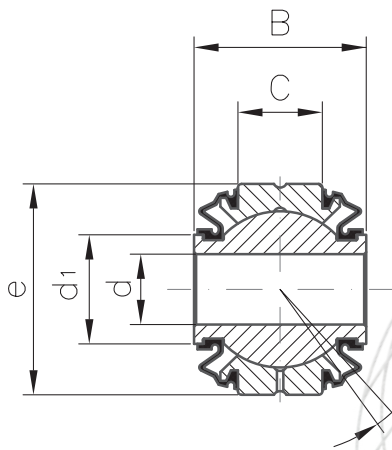

- Special versions:**
- Mating materials steel on high-duty bronze
 - Mating materials steel on steel with anti-friction coating

Designation	d	d ₁	B	C	e	Load rating static C ₀ C ₁	Tilt angle	Weight
Righthand thread	mm	mm	mm	mm	mm	kN	°	kg
S 8-RS	6	11.0	19	9.0	22	31	9	0.035
S 10-RS	8	13.0	21	10.5	26	43	9	0.065
S 12-RS	10	15.5	23	12.0	30	58	9	0.110
S 14-RS	12	17.0	26	13.5	34	74	10	0.150
S 16-RS	14	19.5	28	15.0	38	92	10	0.180
S 18-RS	16	22.5	30	16.5	42	112	10	0.225
S 20-RS	18	24.5	32	18.0	46	135	10	0.300
S 22-RS	20	26.5	35	20.0	50	164	10	0.350
S 25-RS	22	29.5	38	22.0	56	236	10	0.470
S 30-RS	25	35.0	44	25.0	66	273	12	0.690

Mating materials:
Steel on PFFE
Maintenance-free

RS
Special version
RS sealing

Inner ring: Antifriction bearing steel, hardened, ground and polished.

Outer ring: Steel lined with an antifriction film, consisting PTFE.

Rubber bellows: Synthetic rubber.

Tolerances: Acc. To DIN ISO 12240-1, schedule K, except: $d = H8$, $B = +0.3$

Note: With these rod ends, it is important to ensure that the tilt angle specified in the table is not exceeded, either while mounting or during operation, otherwise the rubber bellows may be damaged. Replacement for previous 2RS-version. Available on request.

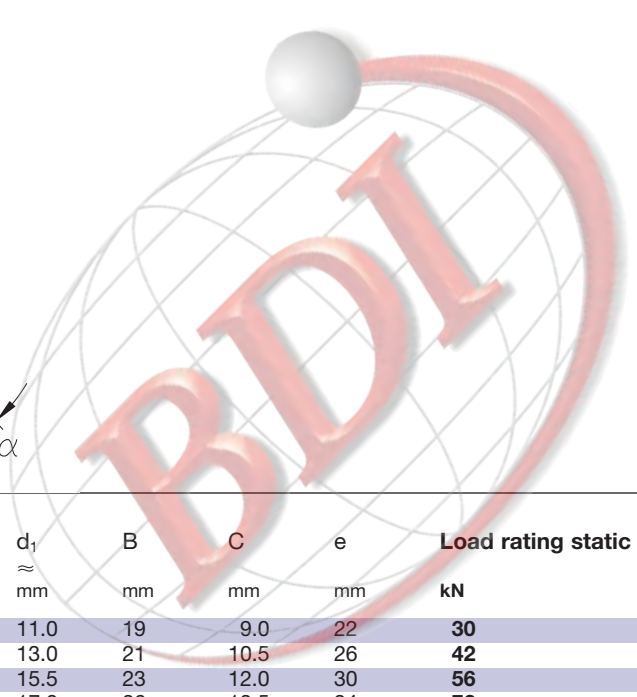
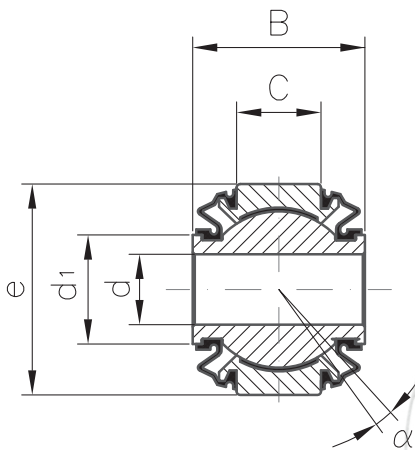

Designation	d	d ₁	B	C	e	Load rating static C ₀	Tilt angle	Weight
Righthand thread	mm	mm	mm	mm	mm	kN	α°	kg
S 8-DRS	6	11.0	19	9.0	22	30	9	0.035
S 10-DRS	8	13.0	21	10.5	26	42	9	0.065
S 12-DRS	10	15.5	23	12.0	30	56	9	0.110
S 14-DRS	12	17.0	26	13.5	34	72	10	0.150
S 16-DRS	14	19.5	28	15.0	38	90	10	0.180
S 18-DRS	16	22.5	30	16.5	42	110	10	0.225
S 20-DRS	18	24.5	32	18.0	46	132	10	0.300
S 22-DRS	20	26.5	35	20.0	50	160	10	0.350
S 25-DRS	22	29.5	38	22.0	56	198	10	0.470
S 30-DRS	25	35.0	44	25.0	66	267	12	0.690

ASKUBAL Rod ends and spherical bearings

Mating materials:
Steel on steel
Maintenance required

DO
 DIN ISO 12240-4
 dimension series E

Inner ring: Antifriction bearing steel, hardened, ground.

Outer ring: Antifriction bearing steel, hardened, ground. Outer ring is split for assembly of inner ring.

Housing: Made of steel, all sizes galvanized and chromatised. The spherical bearing is pressed into the housing and caulked at both sides.

Lubrication nipple: Sizes 6 to 15 without lubricating nipple, sizes 17 to 30 nipple DIN 3405, shape D, further lubricating nipple shapes on request.

Female thread

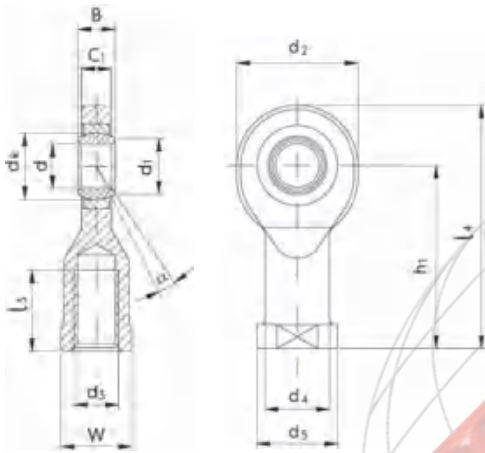

Designation		d	d ₃	B	C ₁	d ₁
Righthand thread	Lefthand thread	mm	mm	mm	max, mm	≈ mm
GIR 6-DO	GIL 6-DO	6	M6	6	4.5	8
GIR 8-DO	GIL 8-DO	8	M8	8	6.5	10
GIR 10-DO	GIL 10-DO	10	M10	9	7.5	13
GIR 12-DO	GIL 12-DO	12	M12	10	8.5	15
GIR 15-DO	GIL 15-DO	15	M14	12	10.5	18
GIR 17-DO	GIL 17-DO	17	M16	14	11.5	20
GIR 20-DO	GIL 20-DO	20	M20x1.5	16	13.5	24
GIR 25-DO	GIL 25-DO	25	M24x2	20	18.0	29
GIR 30-DO	GIL 30-DO	30	M30x2	22	20.0	34
GIR 35-DO	GIL 35-DO	35	M36x3	25	22.0	39
GIR 40-DO	GIL 40-DO	40	M39x3	28	24.0	45
GIR 50-DO	GIL 50-DO	50	M45x3	35	31.0	55
GIR 60-DO	GIL 60-DO	60	M52x3	44	39.0	66
GIR 70-DO	GIL 70-DO	70	M56x4	49	43.0	77
GIR 80-DO	GIL 80-DO	80	M64x4	55	48.0	88

Male thread

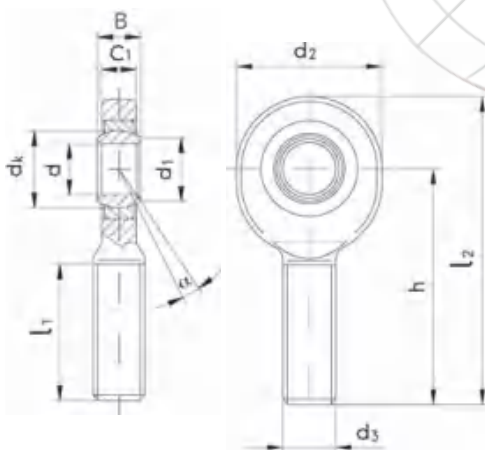

Designation		d	d ₃	B	C ₁	d ₁
Righthand thread	Lefthand thread	mm	mm	mm	max. mm	≈ mm
GAR 6-DO	GAL 6-DO	6	M6	6	4.5	8
GAR 8-DO	GAL 8-DO	8	M8	8	6.5	10
GAR 10-DO	GAL 10-DO	10	M10	9	7.5	13
GAR 12-DO	GAL 12-DO	12	M12	10	8.5	15
GAR 15-DO	GAL 15-DO	15	M14	12	10.5	18
GAR 17-DO	GAL 17-DO	17	M16	14	11.5	20
GAR 20-DO	GAL 20-DO	20	M20x1.5	16	13.5	24
GAR 25-DO	GAL 25-DO	25	M24x2	20	18.0	29
GAR 30-DO	GAL 30-DO	30	M30x2	22	20.0	34
GAR 35-DO	GAL 35-DO	35	M36x3	25	22.0	39
GAR 40-DO	GAL 40-DO	40	M39x3	28	24.0	45
GAR 50-DO	GAL 50-DO	50	M45x3	35	31.0	55
GAR 60-DO	GAL 60-DO	60	M52x3	44	39.0	66
GAR 70-DO	GAL 70-DO	70	M56x4	49	43.0	77
GAR 80-DO	GAL 80-DO	80	M64x4	55	48.0	88



Special versions: available on request

d ₂ max. mm	d ₄ ≈ mm	d ₅ max. mm	dk mm	h ₁ mm	l ₃ min. mm	l ₄ max. mm	W mm	Load rating static C ₀ kN	Tilt angle α°	Weight kg
22	11	14	10	30	11	43	11	8.1	13	0.021
25	13	17	13	36	15	50	13	12.9	15	0.039
30	16	20	16	43	15	60	16	17.6	12	0.061
35	19	23	18	50	18	69	18	24.5	10	0.096
41	22	27	22	61	21	83	21	36.0	8	0.162
47	25	31	25	67	24	92	27	45.0	10	0.233
54	28	36	29	77	30	106	30	60.0	9	0.324
65	35	44	35	94	36	128	36	83.0	7	0.625
75	42	52	40	110	45	149	46	110.0	6	0.976
84	47	60	47	125	60	169	55	146.0	6	1.520
94	52	67	53	142	65	191	60	180.0	7	2.060
114	62	77	66	160	68	219	70	290.0	6	3.570
137	70	90	80	175	70	246	80	450.0	6	5.630
162	80	100	92	200	80	284	85	610.0	6	8.330
182	95	112	105	230	85	324	95	750.0	6	13.040

d ₂ max. mm	dk mm	h mm	l ₁ min. mm	l ₂ max. mm	Load rating static C ₀ kN	Tilt angle α°	Weight kg
22	10	36	16	49	5.5	13	0.017
25	13	42	21	56	10.0	15	0.029
30	16	48	26	65	16.0	12	0.044
35	18	54	28	73	23.0	11	0.066
41	22	63	34	85	32.0	9	0.121
47	25	69	36	94	44.0	10	0.172
54	29	78	43	107	60.0	9	0.283
65	35	94	53	128	83.0	8	0.504
75	40	110	65	149	110.0	7	0.835
84	47	140	82	184	146.0	6	1.410
94	53	150	86	199	180.0	7	1.860
114	66	185	104	244	290.0	6	3.580
137	80	210	115	281	450.0	6	5.730
162	92	235	125	319	610.0	6	7.940
182	105	270	140	364	750.0	6	12.060

Mating materials:
Steel on PTFE
Maintenance-free

UK
 DIN ISO 12240-4
 dimension series E

Inner ring: Antifriction bearing steel, hardened, ground and polished, raceway hard chromium plated.

Outer ring: Free-cutting steel, lined with PTFE.

Housing: Made of steel, all sizes galvanized and chromatised. The spherical bearing is pressed into the housing and caulked at both sides.

Female thread

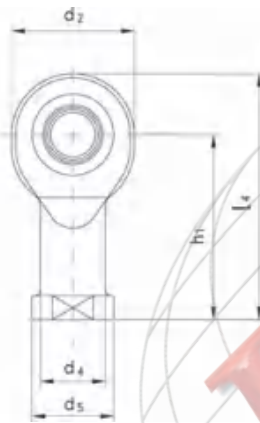
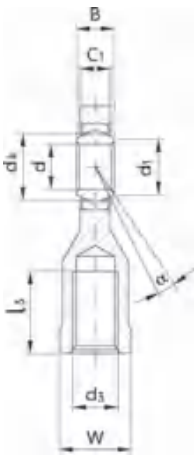

Designation		d	d ₃	B	C ₁ max.	d ₁ ≈
Righthand thread	Lefthand thread	mm	mm	mm	mm	mm
GIR 6-UK	GIL 6-UK	6	M6	6	4.5	8
GIR 8-UK	GIL 8-UK	8	M8	8	6.5	10
GIR 10-UK	GIL 10-UK	10	M10	9	7.5	13
GIR 12-UK	GIL 12-UK	12	M12	10	8.5	15
GIR 15-UK	GIL 15-UK	15	M14	12	10.5	18
GIR 15-UK2RS	GIL 15-UK2RS	15	M14	12	10.5	18
GIR 17-UK	GIL 17-UK	17	M16	14	11.5	20
GIR 17-UK2RS	GIL 17-UK2RS	17	M16	14	11.5	20
GIR 20-UK	GIL 20-UK	20	M20x1.5	16	13.5	24
GIR 20-UK2RS	GIL 20-UK2RS	20	M20x1.5	16	13.5	24
GIR 25-UK	GIL 25-UK	25	M24x2	20	18.0	29
GIR 25-UK2RS	GIL 25-UK2RS	25	M24x2	20	18.0	29
GIR 30-UK	GIL 30-UK	30	M30x2	22	20.0	34
GIR 30-UK2RS	GIL 30-UK2RS	30	M30x2	22	20.0	34
GIR 35-UK2RS	GIL 35-UK2RS	35	M36x3	25	22.0	39
GIR 40-UK2RS	GIL 40-UK2RS	40	M39x3	28	24.0	45
GIR 50-UK2RS	GIL 50-UK2RS	50	M45x3	35	31.0	55
GIR 60-UK2RS	GIL 60-UK2RS	60	M52x3	44	39.0	66
GIR 70-UK2RS	GIL 70-UK2RS	70	M56x4	49	43.0	77
GIR 80-UK2RS	GIL 80-UK2RS	80	M64x4	55	48.0	88

Male thread

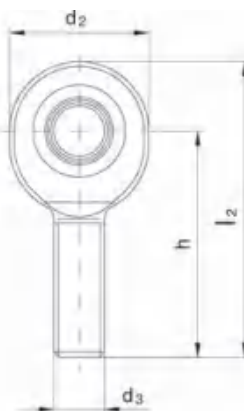
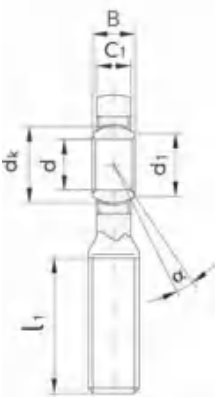

Designation		d	d ₃	B	C ₁ max.	d ₁ ≈
Righthand thread	Lefthand thread	mm	mm	mm	mm	mm
GAR 6-UK	GAL 6-UK	6	M6	6	4.5	8
GAR 8-UK	GAL 8-UK	8	M8	8	6.5	10
GAR 10-UK	GAL 10-UK	10	M10	9	7.5	13
GAR 12-UK	GAL 12-UK	12	M12	10	8.5	15
GAR 15-UK	GAL 15-UK	15	M14	12	10.5	18
GAR 15-UK2RS	GAL 15-UK2RS	15	M14	12	10.5	18
GAR 17-UK	GAL 17-UK	17	M16	14	11.5	20
GAR 17-UK2RS	GAL 17-UK2RS	17	M16	14	11.5	20
GAR 20-UK	GAL 20-UK	20	M20x1.5	16	13.5	24
GAR 20-UK2RS	GAL 20-UK2RS	20	M20x1.5	16	13.5	24
GAR 25-UK	GAL 25-UK	25	M24x2	20	18.0	29
GAR 25-UK2RS	GAL 25-UK2RS	25	M24x2	20	18.0	29
GAR 30-UK	GAL 30-UK	30	M30x2	22	20.0	34
GAR 30-UK2RS	GAL 30-UK2RS	30	M30x2	22	20.0	34
GAR 35-UK2RS	GAL 35-UK2RS	35	M36x3	25	22.0	39
GAR 40-UK2RS	GAL 40-UK2RS	40	M39x3	28	24.0	45
GAR 50-UK2RS	GAL 50-UK2RS	50	M45x3	35	31.0	55
GAR 60-UK2RS	GAL 60-UK2RS	60	M52x3	44	39.0	66
GAR 70-UK2RS	GAL 70-UK2RS	70	M56x4	49	43.0	77
GAR 80-UK2RS	GAL 80-UK2RS	80	M64x4	55	48.0	88



Special versions: available on request

d ₂ max. mm	d ₄ ≈ mm	d ₅ max. mm	dk mm	h ₁ mm	l ₃ min. mm	l ₄ max. mm	W mm	Load rating static C ₀ kN	Tilt angle α°	Weight kg
22	11	14	10	30	11	43	11	8.1	13	0.021
25	13	17	13	36	15	50	13	12.9	15	0.039
30	16	20	16	43	15	60	16	17.6	12	0.061
35	19	23	18	50	18	69	18	24.5	10	0.096
41	22	27	22	61	21	83	21	36.0	8	0.160
41	22	27	22	61	21	83	21	36.0	8	0.160
47	25	31	25	67	24	92	27	45.0	10	0.230
47	25	31	25	67	24	92	27	45.0	10	0.230
54	28	36	29	77	30	106	30	60.0	9	0.320
54	28	36	29	77	30	106	30	60.0	9	0.320
65	35	44	35	94	36	128	36	83.0	7	0.620
65	35	44	35	94	36	128	36	83.0	7	0.620
75	42	52	40	110	45	149	46	110.0	6	0.970
75	42	52	40	110	45	149	46	110.0	6	0.970
84	47	60	47	125	60	169	55	146.0	6	1.500
94	52	67	53	142	65	191	60	180.0	7	2.100
114	62	77	66	160	68	219	70	290.0	6	3.500
137	70	90	80	175	70	246	80	450.0	6	5.600
162	80	100	92	200	80	284	85	610.0	6	8.300
182	95	112	105	230	85	324	95	750.0	6	13.000

d ₂ max. mm	dk mm	h mm	l ₁ min. mm	l ₂ max. mm	Load rating static C ₀ kN	Tilt angle α°	Weight kg
22	10	36	16	49	5.5	13	0.017
25	13	42	21	56	10.0	15	0.029
30	16	48	26	65	16.0	12	0.044
35	18	54	28	73	23.0	10	0.066
41	22	63	34	85	32.0	8	0.120
41	22	63	34	85	32.0	8	0.120
47	25	69	36	94	44.0	10	0.170
47	25	69	36	94	44.0	10	0.170
54	29	78	43	107	60.0	9	0.280
54	29	78	43	107	60.0	9	0.280
65	35	94	53	128	83.0	7	0.510
65	35	94	53	128	83.0	7	0.510
75	40	110	65	149	110.0	6	0.840
75	40	110	65	149	110.0	6	0.840
84	47	140	82	184	146.0	6	1.400
94	53	150	86	199	180.0	7	1.800
114	66	185	104	244	290.0	6	3.600
137	80	210	115	281	450.0	6	5.700
162	92	235	125	319	610.0	6	7.900
182	105	270	140	364	750.0	6	12.000

Mating materials:
Steel on steel
Maintenance required

DO
 DIN ISO 12240-1
 dimension series E

Inner ring: Antifriction bearing steel, hardened, ground.

Outer ring: Antifriction bearing steel, hardened, ground. Outer ring is split for assembly of inner ring.

Lubrication: Sizes 6 to 15 without lubrication groove and lubrication hole. From size 17 upwards, relubrication is also possible through the inner bore.

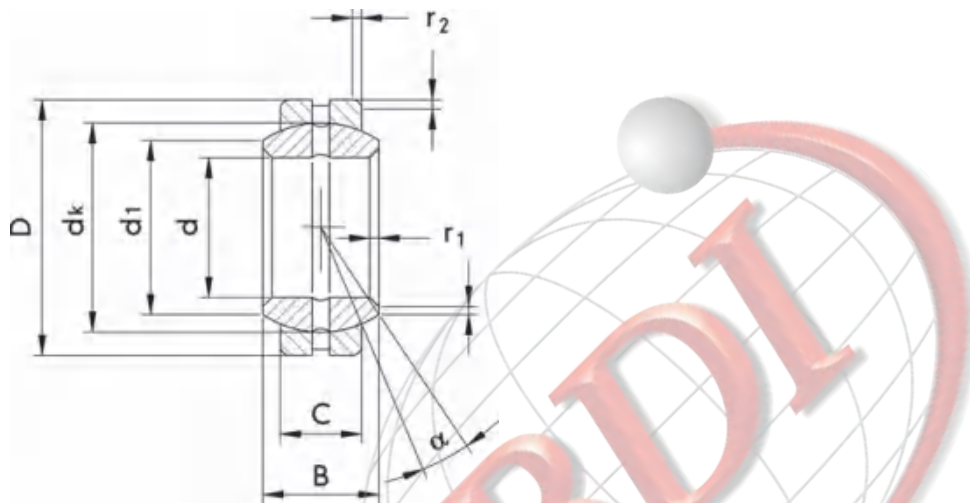

Designation	d	d ₁	B	C	D	dk	r ₁	r ₂	Load rating static C ₀	Tilt angle	Weight
	mm	≈ mm	mm	mm	mm	mm	min. mm	min. mm	kN	≈ °	kg
GE 6-DO	6	8	6	4	14	10	0.3	0.3	17	13	0.004
GE 8-DO	8	10	8	5	16	13	0.3	0.3	27	15	0.008
GE 10-DO	10	13	9	6	19	16	0.3	0.3	40	12	0.011
GE 12-DO	12	15	10	7	22	18	0.3	0.3	53	10	0.015
GE 15-DO	15	18	12	9	26	22	0.3	0.3	84	8	0.027
GE 17-DO	17	20	14	10	30	25	0.3	0.3	106	10	0.041
GE 20-DO	20	24	16	12	35	29	0.3	0.3	146	9	0.066
GE 25-DO	25	29	20	16	42	35	0.6	0.6	240	7	0.119
GE 30-DO	30	34	22	18	47	40	0.6	0.6	310	6	0.153
GE 35-DO	35	39	25	20	55	47	0.6	1.0	399	6	0.233
GE 40-DO	40	45	28	22	62	53	0.6	1.0	495	7	0.306
GE 45-DO	45	50	32	25	68	60	0.6	1.0	637	7	0.427
GE 50-DO	50	55	35	28	75	66	0.6	1.0	780	6	0.939
GE 60-DO	60	66	44	36	90	80	1.0	1.0	1220	6	1.040
GE 70-DO	70	77	49	40	105	92	1.0	1.0	1560	6	1.550
GE 80-DO	80	88	55	45	120	105	1.0	1.0	2000	6	2.310
GE 90-DO	90	98	60	50	130	115	1.0	1.0	2440	5	2.750
GE 100-DO	100	109	70	55	150	130	1.0	1.0	3030	7	4.450
GE 110-DO	110	120	70	55	160	140	1.0	1.0	3270	6	4.820
GE 120-DO	120	130	85	70	180	160	1.0	1.0	4750	6	8.050
GE 140-DO	140	150	90	70	210	180	1.0	1.0	5350	7	11.020
GE 160-DO	160	170	105	80	230	200	1.0	1.0	6800	8	14.010
GE 180-DO	180	192	105	80	260	225	1.1	1.1	7650	6	18.650
GE 200-DO	200	212	130	100	290	250	1.1	1.1	10600	7	28.030

Mating materials:
Steel on steel
Maintenance required

FO
DIN ISO 12240-1
dimension series G

Inner ring: Antifriction bearing steel, hardened, ground.

Outer ring: Antifriction bearing steel, hardened, ground. Outer ring is split for assembly of inner ring.

Lubrication: Lubrication groove and lubrication hole, relubrication is also possible through the inner bore.

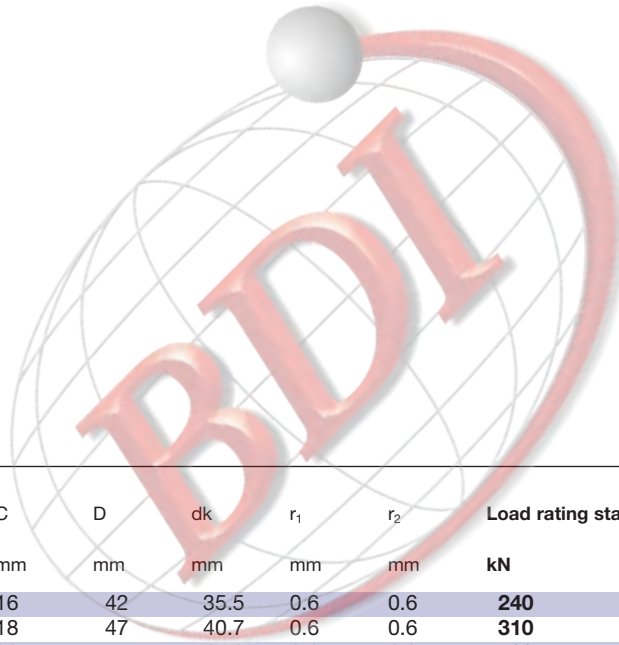
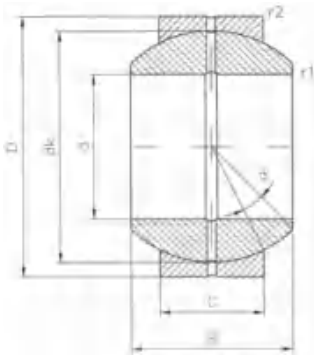

Designation	d	B	C	D	dk	r ₁	r ₂	Load rating static C ₀	Tilt angle	Weight
	mm	mm	mm	mm	mm	mm	mm	kN	α°	kg
GE 20-FO	20	25	16	42	35.5	0.6	0.6	240	17	0.15
GE 25-FO	25	28	18	47	40.7	0.6	0.6	310	17	0.19
GE 30-FO	30	32	20	55	47.0	0.6	1.0	400	17	0.29
GE 35-FO	35	35	23	62	53.0	0.6	1.0	500	16	0.39
GE 40-FO	40	40	25	68	60.0	0.6	1.0	640	17	0.52
GE 45-FO	45	43	28	75	66.0	0.6	1.0	780	15	0.68
GE 50-FO	50	56	36	90	80.0	0.6	1.0	1120	17	1.40
GE 60-FO	60	63	40	105	92.0	1.0	1.0	1560	17	2.00
GE 70-FO	70	70	45	120	105.0	1.0	1.0	2000	16	2.90
GE 80-FO	80	75	50	130	115.0	1.0	1.0	2450	14	3.50
GE 90-FO	90	85	55	150	130.0	1.0	1.0	3050	15	5.40
GE 100-FO	100	85	55	160	140.0	1.0	1.0	3250	14	5.90

Mating materials:
Steel on steel
Maintenance required

LO
 DIN ISO 12240-1
 dimension series W

Inner ring: Antifriction bearing steel, hardened, ground.

Outer ring: Antifriction bearing steel, hardened, ground. Outer ring is split for assembly of inner ring.

Lubrication: Lubrication groove and lubrication hole, relubrication is also possible through the inner bore.

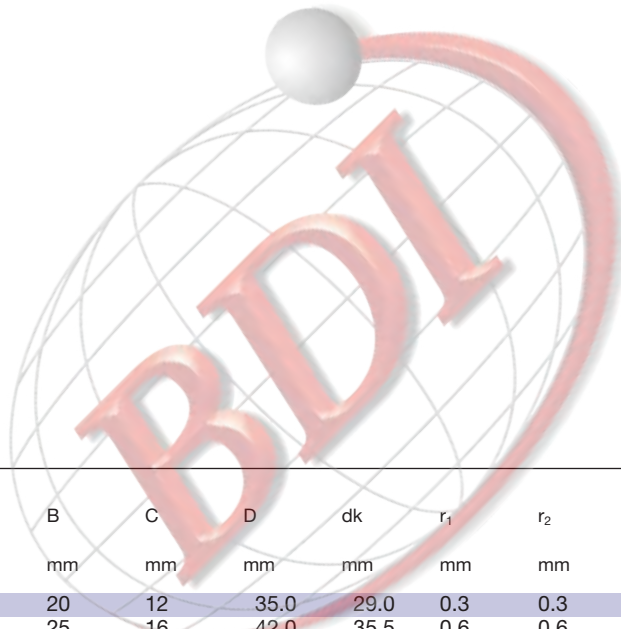
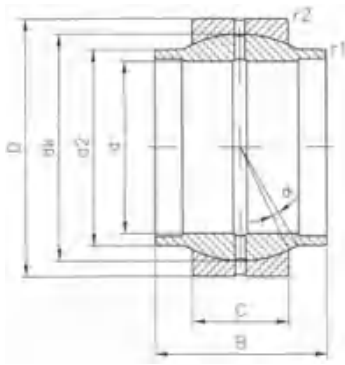

Designation	d	d ₂ min. mm	B	C	D	dk	r ₁	r ₂	Load rating static C ₀ kN	Tilt angle ∞°	Weight kg
GE 20-LO	20	25.0	20	12	35.0	29.0	0.3	0.3	146	4	0.070
GE 25-LO	25	30.0	25	16	42.0	35.5	0.6	0.6	240	4	0.120
GE 32-LO	32	38.0	32	18	52.0	44.0	0.6	1.0	335	4	0.200
GE 40-LO	40	46.0	40	22	62.0	53.0	0.6	1.0	500	4	0.340
GE 50-LO	50	57.0	50	28	75.0	66.0	0.6	1.0	780	4	0.560
GE 63-LO	63	71.5	63	36	95.0	83.0	0.1	1.0	1270	4	1.200
GE 70-LO	70	79.0	70	40	105.0	92.0	1.0	1.0	1560	4	1.700
GE 80-LO	80	91.0	80	45	120.0	105.0	1.0	1.0	2000	4	2.400

Mating materials:
Steel on PTFE
Maintenance-free

UK
DIN ISO 12240-1
dimension series E

Inner ring: Antifriction bearing steel, hardened, ground and polished.

Outer ring: Steel, lined with PTFE.

Sealing: Sealing rings at both sides.

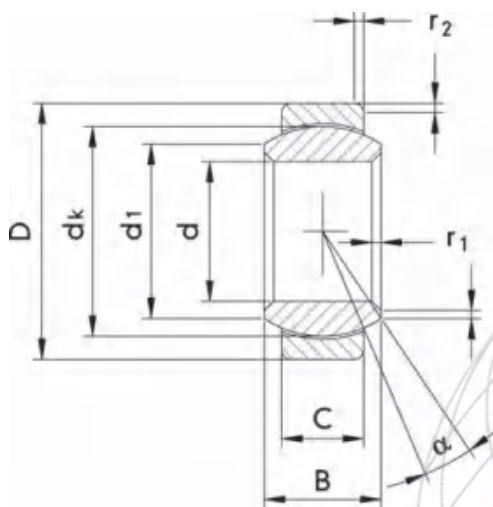

Designation	d	d ₁	B	C	D	dk	r ₁	r ₂	Load rating static C ₀	Tilt angle	Weight
	mm	≈ mm	mm	mm	mm	mm	min. mm	min. mm	kN	≈ °	kg
GE 6-UK	6	8	6	4	14	10	0.3	0.3	9	13	0.004
GE 8-UK	8	10	8	5	16	13	0.3	0.3	14	15	0.008
GE 10-UK	10	13	9	6	19	16	0.3	0.3	21	12	0.011
GE 12-UK	12	15	10	7	22	18	0.3	0.3	28	10	0.015
GE 15-UK	15	18	12	9	26	22	0.3	0.3	45	8	0.027
GE 17-UK	17	20	14	10	30	25	0.3	0.3	56	10	0.041
GE 17-UK2RS	17	20	14	10	30	25	0.3	0.3	60	10	0.041
GE 20-UK	20	24	16	12	35	29	0.3	0.3	78	9	0.066
GE 20-UK2RS	20	24	16	12	35	29	0.3	0.3	83	9	0.066
GE 25-UK	25	29	20	16	42	35	0.6	0.6	127	7	0.119
GE 25-UK2RS	25	29	20	16	42	35	0.6	0.6	137	7	0.119
GE 30-UK	30	34	22	18	47	40	0.6	0.6	166	6	0.153
GE 30-UK2RS	30	34	22	18	47	40	0.6	0.6	176	6	0.153
GE 35-UK2RS	35	39	25	20	55	47	0.6	1.0	224	6	0.233
GE 40-UK2RS	40	45	28	22	62	53	0.6	1.0	280	7	0.306
GE 45-UK2RS	45	50	32	25	68	60	0.6	1.0	360	7	0.427
GE 50-UK2RS	50	55	35	28	75	66	0.6	1.0	440	6	0.939
GE 60-UK2RS	60	66	44	36	90	80	1.0	1.0	695	6	1.040
GE 70-UK2RS	70	77	49	40	105	92	1.0	1.0	880	6	1.550
GE 80-UK2RS	80	88	55	45	120	105	1.0	1.0	1140	6	2.310
GE 90-UK2RS	90	98	60	50	130	115	1.0	1.0	1370	5	2.750
GE 100-UK2RS	100	109	70	55	150	130	1.0	1.0	1730	7	4.450
GE 110-UK2RS	110	120	70	55	160	140	1.0	1.0	1860	6	4.820
GE 120-UK2RS	120	130	85	70	180	160	1.0	1.0	2700	6	8.050

Mating materials:
Steel on PTFE
Maintenance-free

TGR
DIN ISO 12240-1
dimension series E

Inner ring: Stainless steel, hardened, ground and polished.
Outer ring: Stainless steel lined with PTFE, cold formed around the inner ring.

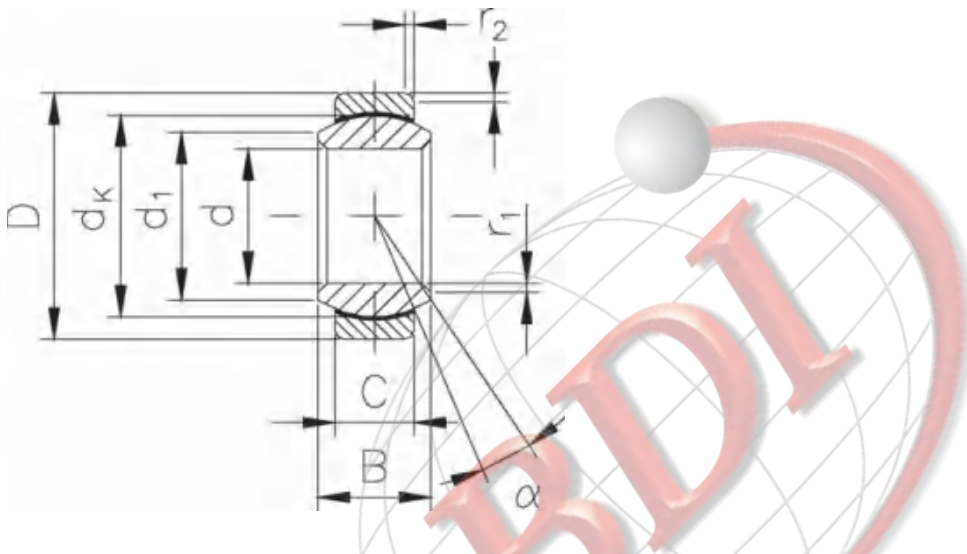

Designation	d	d ₁	B	C	D	dk	r ₁	r ₂	Load rating static C ₀	Tilt angle	Weight
	mm	mm	mm	mm	mm	mm	mm	mm	kN	°	kg
GE 8-TGR	8	10	8	5	16	13.0	0.5	0.5	15	15	0.008
GE 10-TGR	10	13	9	6	19	16.0	0.8	0.5	22	12	0.012
GE 12-TGR	12	15	10	7	22	18.0	0.8	0.8	29	11	0.017
GE 15-TGR	15	18	12	9	26	22.0	0.8	0.8	44	9	0.032
GE 17-TGR	17	20	14	10	30	25.0	0.8	0.8	56	10	0.049
GE 20-TGR	20	24	16	12	35	29.0	0.8	1.0	78	9	0.065
GE 25-TGR	25	29	20	16	42	35.5	0.8	1.0	127	8	0.115
GE 30-TGR	30	34	22	18	47	40.7	0.8	1.0	166	7	0.160

Mating materials:
Steel on steel
Maintenance required

DO2RS
 DIN ISO 12240-1
 dimension series E
 2RS sealing

Inner ring: Antifriction bearing steel, hardened, ground.
Outer ring: Antifriction bearing steel, hardened, ground. Outer ring is split for assembly of inner ring.
Sealing: Sealing rings at both sides.
Lubrication: Sizes 6 to 15 without lubrication groove and lubrication hole. Form size 17 upwards, relubrication is also possible through the inner bore.

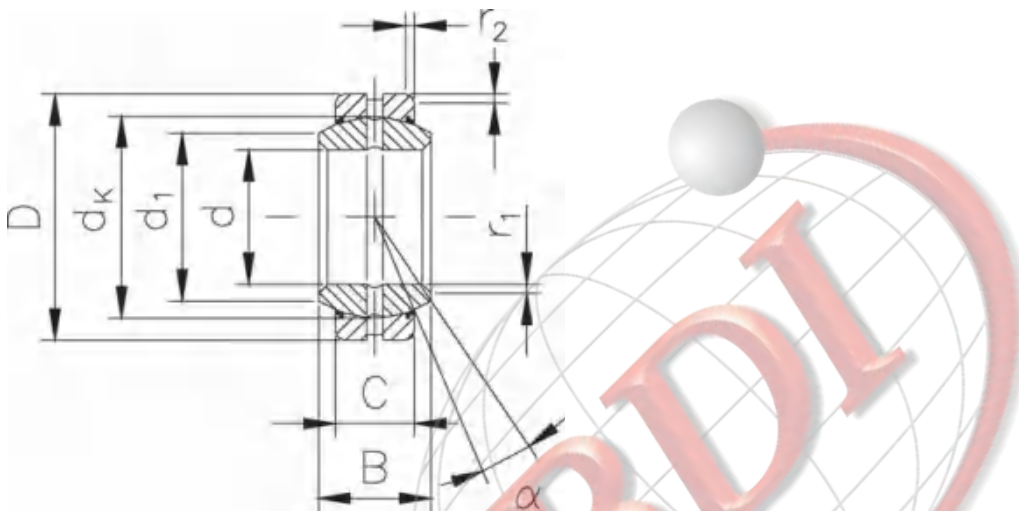

Designation	d	d ₁	B	C	D	dk	r ₁	r ₂	Load rating static C ₀	Tilt angle	Weight
	mm	mm	mm	mm	mm	mm	mm	mm	kN	α°	kg
GE 15-DO2RS	15	18	12	9	26	22.0	0.8	0.8	84	9	0.032
GE 17-DO2RS	17	20	14	10	30	25.0	0.8	0.8	106	10	0.049
GE 20-DO2RS	20	24	16	12	35	29.0	0.8	1.0	146	9	0.065
GE 25-DO2RS	25	29	20	16	42	35.5	0.8	1.0	240	8	0.115
GE 30-DO2RS	30	34	22	18	47	40.7	0.8	1.0	310	7	0.160
GE 35-DO2RS	35	39	25	20	55	47.0	1.0	1.2	399	7	0.258
GE 40-DO2RS	40	45	28	22	62	53.0	1.0	1.2	495	7	0.315
GE 45-DO2RS	45	50	32	25	68	60.0	1.0	1.2	637	8	0.413
GE 50-DO2RS	50	56	35	28	75	66.0	1.0	1.2	780	7	0.560
GE 60-DO2RS	60	66	44	36	90	80.0	1.2	1.5	1220	7	1.100
GE 70-DO2RS	70	77	49	40	105	92.0	1.2	1.5	1560	6	1.540
GE 80-DO2RS	80	89	55	45	120	105.0	1.2	1.5	2000	6	2.290

Mating materials:
Steel on steel
Maintenance required

FO2RS
 DIN ISO 12240-1
 dimension series G
 2RS-sealing

- Inner ring:** Antifriction bearing steel, hardened, ground.
- Outer ring:** Antifriction bearing steel, hardened, ground. Outer ring is split for assembly of inner ring.
- Lubrication:** Lubrication groove and lubrication hole, relubrication is also possible through the inner bore.
- Sealing:** Sealing rings at both sides.

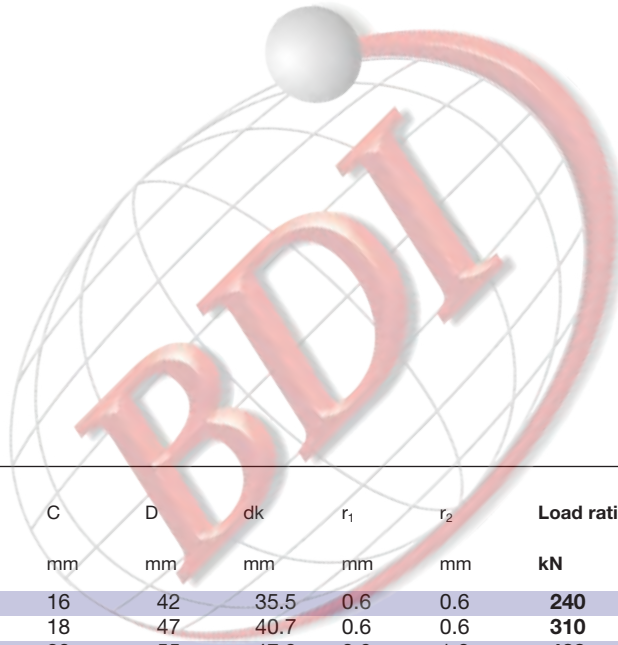
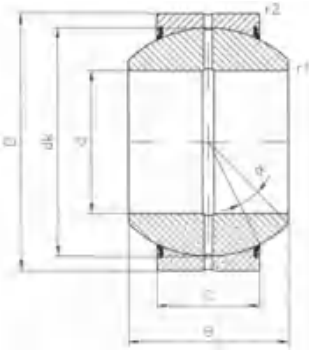

Designation	d	B	C	D	dk	r ₁	r ₂	Load rating static C ₀	Tilt angle	Weight
	mm	mm	mm	mm	mm	mm	mm	kN	°	kg
GE 20-FO2RS	20	25	16	42	35.5	0.6	0.6	240	17	0.15
GE 25-FO2RS	25	28	18	47	40.7	0.6	0.6	310	17	0.19
GE 30-FO2RS	30	32	20	55	47.0	0.6	1.0	400	17	0.29
GE 35-FO2RS	35	35	23	62	53.0	0.6	1.0	500	16	0.39
GE 40-FO2RS	40	40	25	68	60.0	0.6	1.0	640	17	0.52
GE 45-FO2RS	45	43	28	75	66.0	0.6	1.0	780	15	0.68
GE 50-FO2RS	50	56	36	90	80.0	0.6	1.0	1120	17	1.40
GE 60-FO2RS	60	63	40	105	92.0	1.0	1.0	1560	17	2.00
GE 70-FO2RS	70	70	45	120	105.0	1.0	1.0	2000	16	2.90
GE 80-FO2RS	80	75	50	130	115.0	1.0	1.0	2450	14	3.50
GE 90-FO2RS	90	85	55	150	130.0	1.0	1.0	3050	15	5.40
GE 100-FO2RS	100	85	55	160	140.0	1.0	1.0	3250	14	5.90

Mating materials:
Steel on steel
Maintenance required

HO2RS
2RS-sealing

- Inner ring:** Antifriction bearing steel, hardened, ground.
Outer ring: Antifriction bearing steel, hardened, ground. Outer ring is split for assembly of inner ring.
Lubrication: Lubrication groove and lubrication hole, relubrication is also possible through the inner bore.
Radial clearance: see technical basics, table spherical bearings dimension series E, mating materials steel on steel.
Sealing: Sealing rings at both sides.

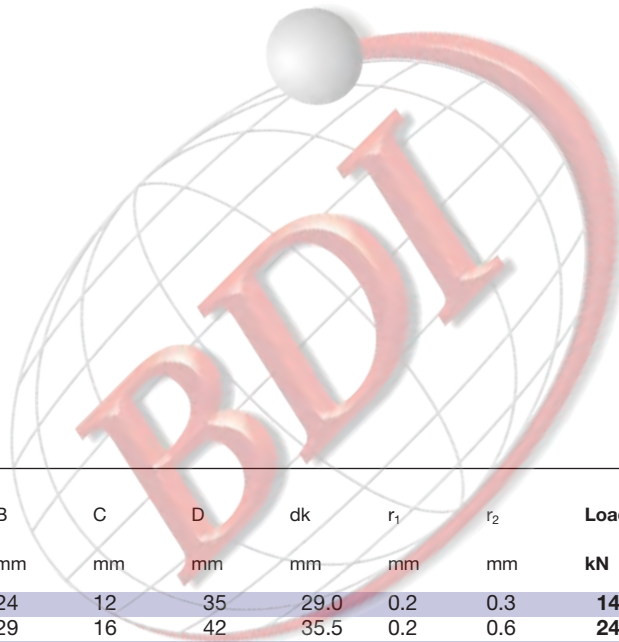
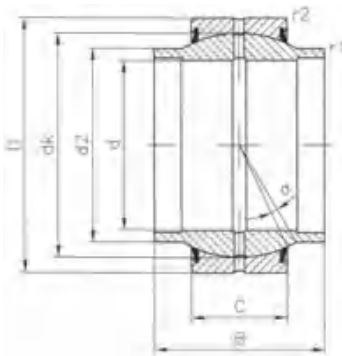

Designation	d	d ₂ min. mm	B	C	D	dk	r ₁	r ₂	Load rating static C ₀	Tilt angle	Weight
	mm		mm	mm	mm	mm	mm	mm	kN	α°	kg
GE 20-HO2RS	20	24.0	24	12	35	29.0	0.2	0.3	146	3	0.057
GE 25-HO2RS	25	29.0	29	16	42	35.5	0.2	0.6	240	3	0.100
GE 30-HO2RS	30	34.2	30	18	47	40.7	0.2	0.6	310	3	0.140
GE 35-HO2RS	35	40.0	35	20	55	47.0	0.3	1.0	400	3	0.240
GE 40-HO2RS	40	45.0	38	22	62	53.0	0.3	1.0	500	3	0.290
GE 45-HO2RS	45	51.5	40	25	68	60.0	0.3	1.0	640	3	0.430
GE 50-HO2RS	50	56.5	43	28	75	66.0	0.3	1.0	780	3	0.540
GE 60-HO2RS	60	67.7	54	36	90	80.0	0.3	1.0	1220	3	1.100
GE 70-HO2RS	70	78.0	65	40	105	92.0	0.3	1.0	1560	3	1.600
GE 80-HO2RS	80	90.0	74	45	120	105.0	0.3	1.0	2000	3	2.400